



RoHS
Compliant

Winmaster 2

630A ~ 3200A



Air Circuit Breaker

Breaker with intelligence

WiNmaster2 Power Circuit Breakers are a new generation of Air Circuit Breakers having modular construction to offer a truly global product platform meeting IEC, ANSI and UL standards.

A line of Three and Four pole devices ranging from 630 to 3200 Amp in two basic frames with fault interruption ratings of up to 65kA. A design offering a unique combination of High Fault current withstands ratings, short fault interruption time and zone selectivity.

The device includes the new state-of-the-art MicroPro2 intelligent trip unit that enables the circuit breaker with the latest technology for system safety, reliability, measurement, relaying and communications using the Modbus, Profibus or devicenet protocol.





CONTENTS

| | |
|-------------------------------|-------|
| Introduction | 7 |
| Constructions Characteristics | 8-13 |
| ROHS Compliant | 14-15 |
| Technical Characteristics | 16-17 |
| Connection Installation | 18-19 |
| External Configuration | 20-21 |
| Intelligent Trip Units | 22-35 |
| Characteristic Curves | 36-47 |
| Communication | 48 |
| ZSI (micropro2) | 49 |
| Accessories | 50-53 |
| Electrical Diagram | 54-55 |
| Identifying ACB | 56-57 |
| Dimensions | 58-60 |





Complete Modular construction

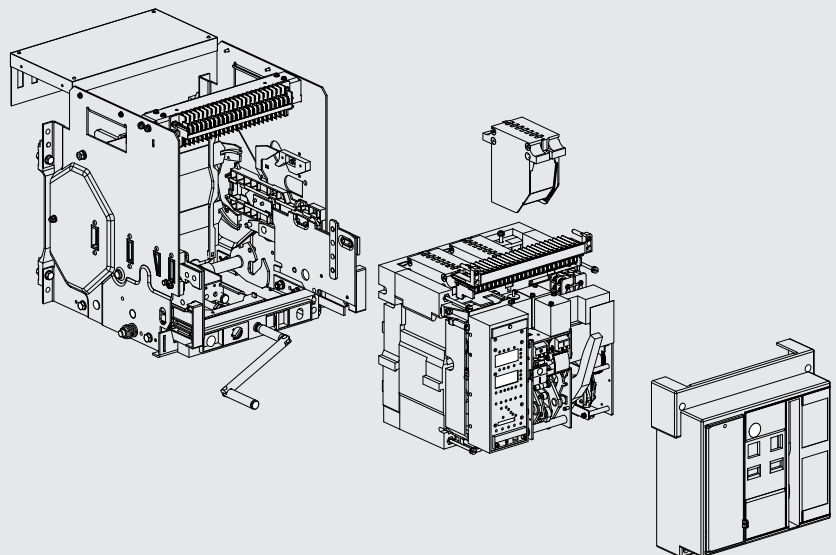

WiNmaster 2 - WX Series ACB

- Range: 630A~3200A
- Two frame sizes for complete range

- Intelligent release
 - Micropro 2-3.1
 - Micropro 2-4.1
 - Micropro 2-7.1

- Communication
 - RS-485/232
 - Modbus
 - Profibus
 - Devicenet



The new WiNmaster2 ACBs are the result of constant commitment to look for new solutions and the know how C&S has developed over the years.

In this series C&S introduces New WiNmaster2 Air Circuit Breaker which is an incredibly innovative high quality circuit-breaker supported by state-of-the-art manufacturing technologies which ensures utmost performance, reliability, complete safety and uninterruptible service throughout the product life that ultimately reduces the stress on components.

WiNmaster2 Air Circuit Breaker is available from 630A to 3200 A rating in 3 and 4 pole execution, with breaking capacity of 50kA / 65kA. It provides total solutions with an advanced trip relay for measurement, diagnosis, analysis, and communication as well as protective functions for absolute protective coordination and electric power monitoring system.

WiNmaster 2 has a modular construction which has been designed according to customer's demand and present day complex requirement of electrical systems.

These ACBs are most compact in size with wide range & high breaking capacity. Compact yet offering Horizontal Type Busbar Termination for ease of installation enhanced life and intuitive operation makes them a very user friendly range of circuit breaker for any application. The height and depth are same through out the range. The accessories are common, front accessible and easy to fit up to 3200 A

WiNmaster2 ACB stands for...Reliability as it confirms to the latest IEC 60947-2/IS 13947-2 standard for Isolation.



Available in both Fixed & Drawout version

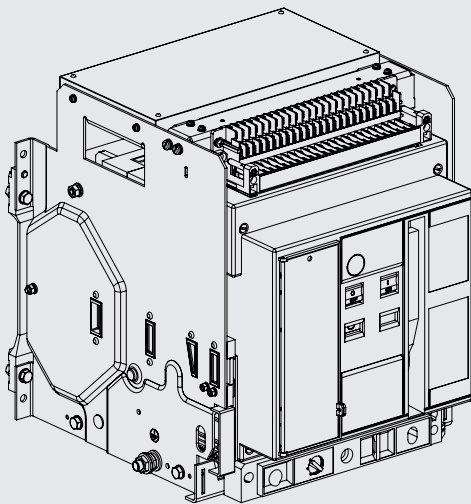

Fixed Type

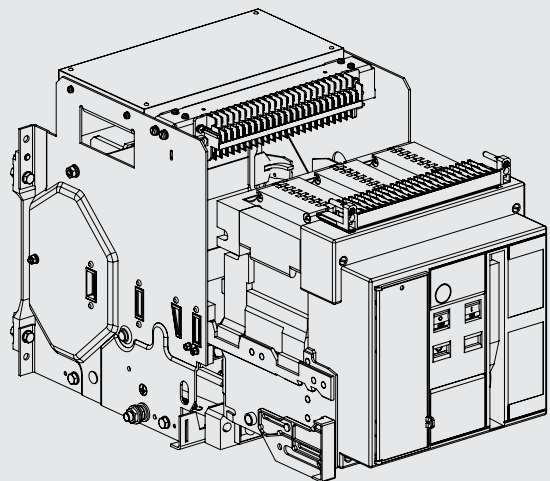

Drawout Type

Constructions Characteristics

Structure of the Circuit Breaker

The sheet steel structure of WiNmaster 2 is extremely compact, considerably reducing overall dimensions.

WiNmaster 2 circuit breakers comes in two frame sizes.

WX-A: 630A to 2500A

WX-B: 2000A to 3200A

| Performance levels: | | 50kA (N) | 65kA (H) |
|---------------------|-------|----------|----------|
| WX-A | WX06A | ■ | |
| | WX08A | ■ | |
| | WX10A | ■ | |
| | WX12A | ■ | |
| | WX16A | ■ | |
| | WX20A | ■ | |
| | WX25A | ■ | |
| WX-B | WX20B | | ■ |
| | WX25B | | ■ |
| | WX32B | | ■ |

Uniform Construction

..... Offering ease for installation and possibility for optimized panel size.

The height and width are showing below for frame WX-A up to 2500A. The panel cutout size is same for all types of WiNmaster2, which makes it easy to arrange them in switchboards. Panel cutout for front remains same.

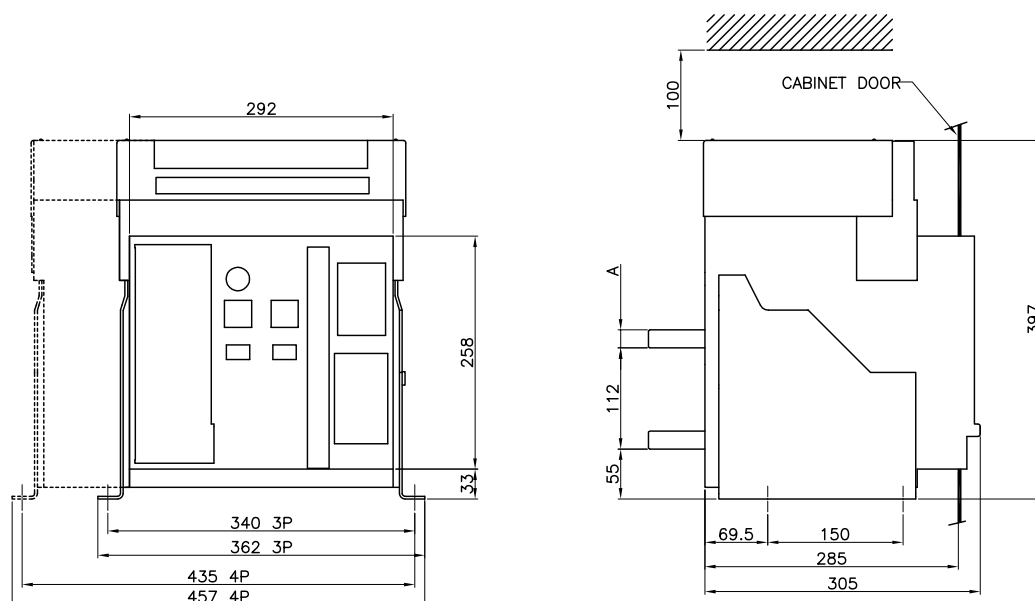

Contact System

Contact system of each phase is installed in a small chamber that is made up of insulating materials, with arc-extinguish chamber above it. Contact system is connected with the main shaft outside the insulating base through connecting rod, so as to finish the closing and opening operations.

In order to reduce the electric repulsion and improve the reliability, contact system of each phase adopts parallel connection of 10~14 moving contacts that are installed on a contact support.

One end of contacting piece of the contact is connected with the busbar through flexible connection.

When the circuit breaker closes, the main shaft drives the connecting rod to make the contact support revolve around the point "A" counterclockwise, after the moving contact touches the static contact, the contact support will continue to rotate around the point "A" counterclockwise, while the moving contact will rotate around the point "B" clockwise to compress the spring, so as to produce a certain contact force that guarantees reliable closing of circuit breaker.

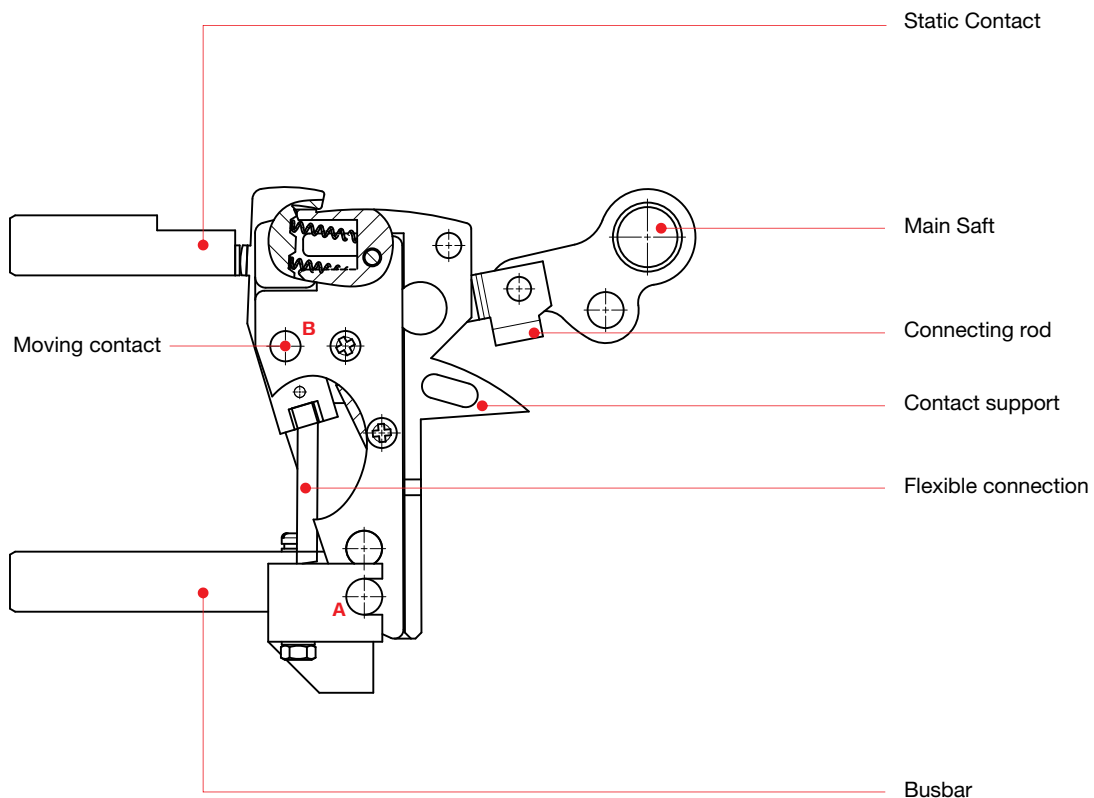

Operating Mechanism

The operation of circuit breaker has two modes: manual operation and electric operation. Operating mechanism of circuit breaker makes use of cam to compress a group of energy-storage spring to reach the aim of energy storing, makes use of the energy of energy-storage spring during releasing to close the circuit breaker, the closing speed has no relation to electric or manual operating speed. Circuit breaker will carry out energy pre-storage under closing state for the next closing. The operating mechanism has function of free tripping. The circuit breaker has three types of working position, whose operating process as follows:

Energy storage

External force of electric operation or manual operation drives the cam to rotate, the energy-storage lever on the cam rotates along with it. During the rotation of cam, energy-storage spring is compressed continuously until the cam rotates to a certain angle (finish position of energy storage); the reaction force of energy-storage lever will push the cam to go on rotating (turn to energy releasing position), in the meantime, the fixed shaft on the cam is just pressed against the lever 1, and the other end of lever 1 is locked by the energy-releasing tripping half-shaft, so the “go on rotating” of cam also is locked (in energy-storage position). On the other hand, when the external force of electric operation or manual operation helps the energy storing of energy-storage spring, cam drives the connecting rod 1 to rotate, the lever 2 on connecting rod 1 rotates towards the re-trip position, when reaching the re-trip position, the tripping half-shaft is rotated to the re-trip position under the action of spring force on the re-trip half-shaft, so as to finish the re-trip process. Now the energy storage is finished, it is ready for closing of circuit breaker.

Closing

Press the closing button or closing electromagnet, let the half-shaft of energy-releasing release rotate counterclockwise, then the lever 1 pressing against the energy-releasing tripping half-shaft trips, cam rotates clockwise under the action of energy-storage spring force until reaching the cam gap, energy-storage lever rotates counterclockwise under the action of energy-storage spring force, axle pin on the energy-storage lever just hits the connecting rod 2 fiercely, which enables the connecting rod 2 to rotate, and drives the connecting rod 1 and connecting rod 3 to run, as the running direction (by means of force transmission of lever 2) of connecting rod 1 is locked by the tripping half-shaft, then the connecting rod 3 pushes the main shaft 8 to rotate clockwise, to close the circuit breaker.

Breaking

Let the shunt tripping half-shaft (10) rotate clockwise by pressing the opening button or through the tripping operation from under-voltage release, shunt release and intelligent release, lever 2 trips, force pressing against the connecting rod 1 is disappeared, and now the connecting rod 1 is in free state, the four-rod link mechanism composed of connecting rod 1, 2 and 3 now becomes five-rod linkage mechanism, under the action of contact reaction force and backspring force, the circuit breaker opens quickly.

Electric energy-storage mechanism

The electric energy-storage mechanism is composed of motor, position limited inching switch and a group of gear reduction system that has planetary gear, used for energy storing and energy pre-storing of operating mechanism.

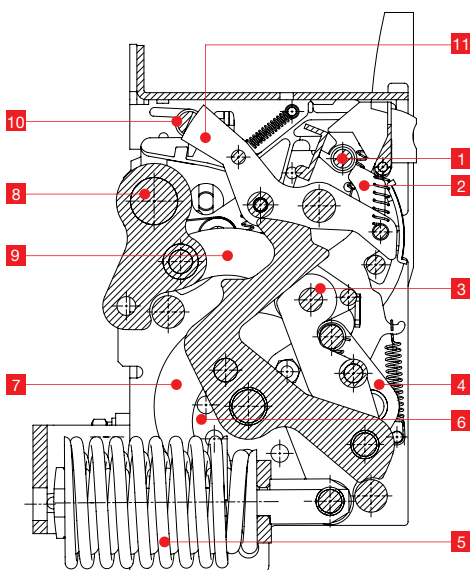

- 1 Energy releasing tripping half-shaft
- 2 Lever
- 3 Connecting rod 2
- 4 Energy storage lever
- 5 Energy storage spring
- 6 Cam
- 7 Connecting rod 1
- 8 Main shaft
- 9 Connecting rod 3
- 10 Breaking tripping -shaft
- 11 Lever 2

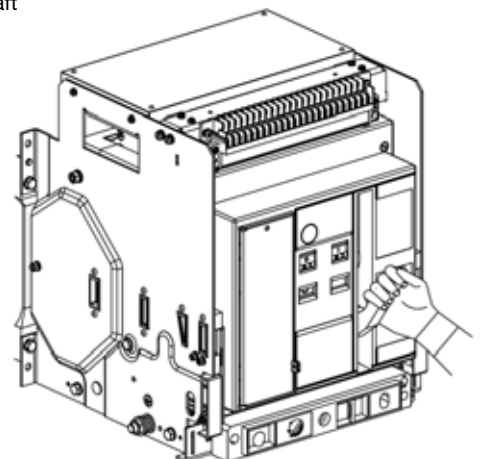

Constructions Characteristics

Basic Structure

WiNmaster2 WX series circuit breakers are available in Drawout & fixed versions. The drawout version is mounted on a chassis & the fixed version is installed using fixing brackets.

Drawout version

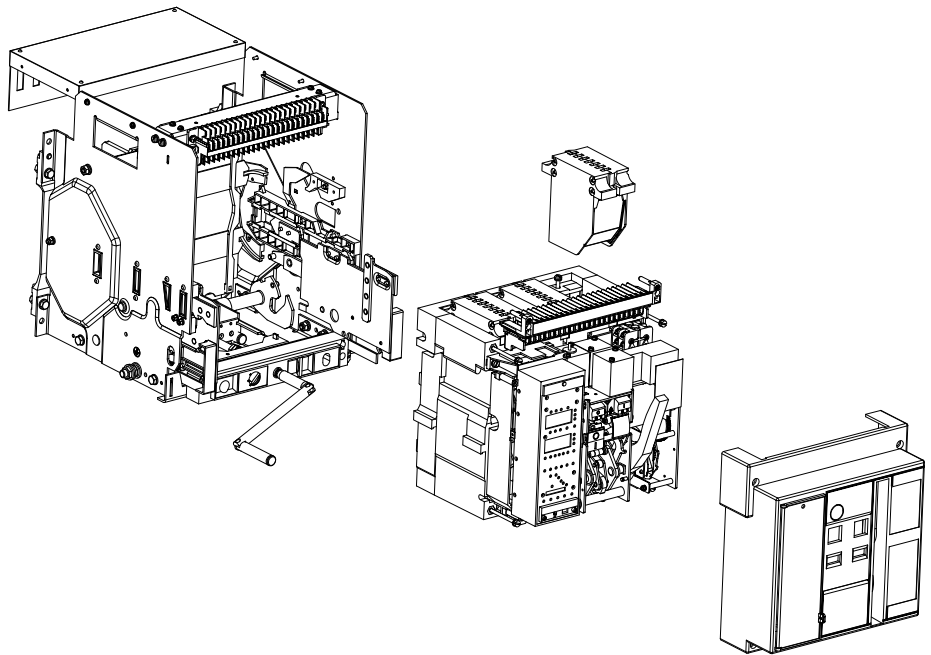

Fixed version

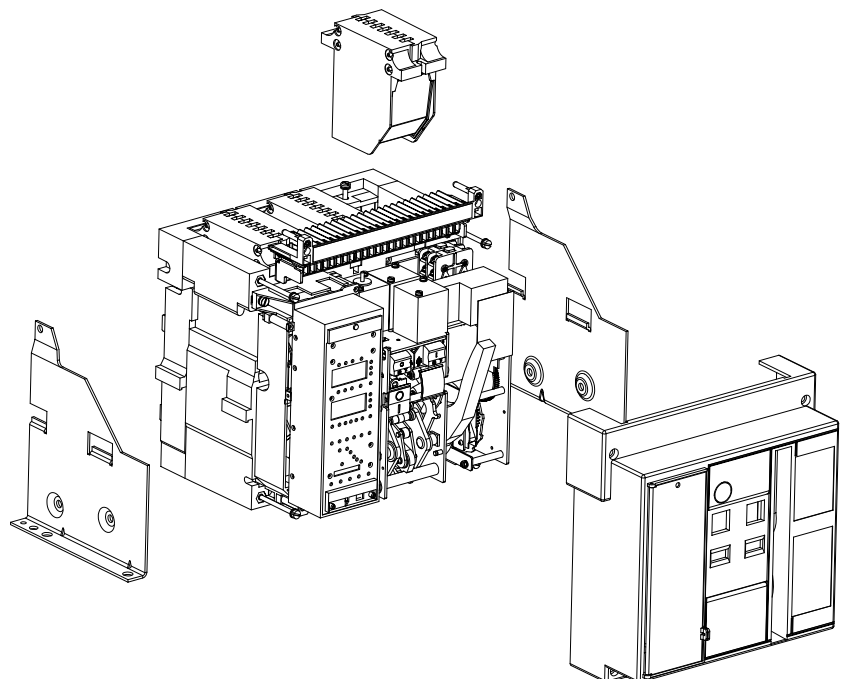

Constructions Characteristics

Chassis

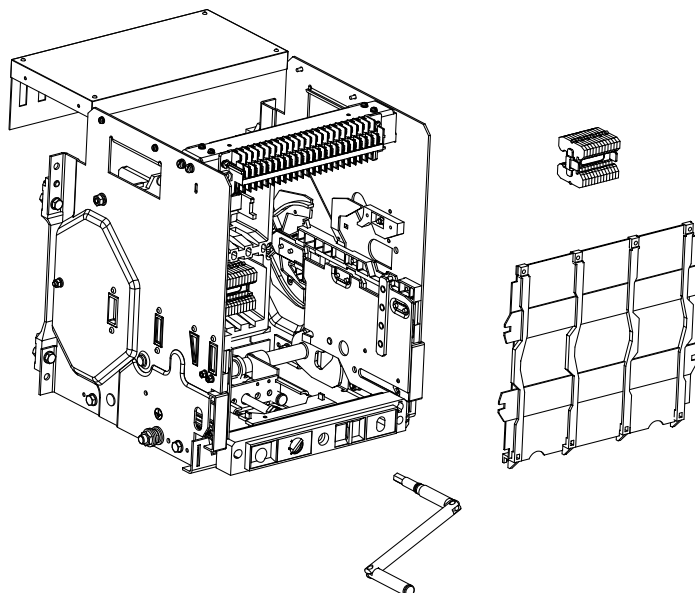

Circuit breaker

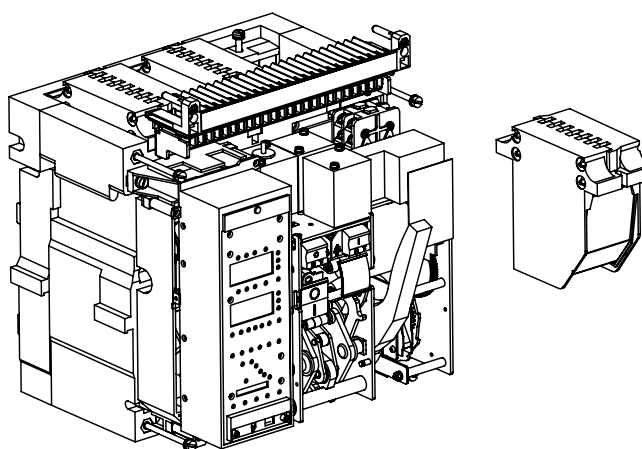

Front cover

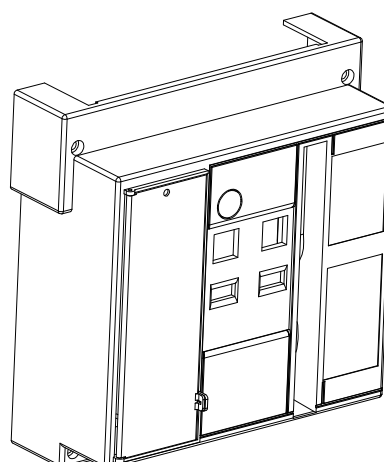



RoHS Compliant

WiNmaster2 ACB is a product conforming to RoHS (Restriction of Hazardous Substances) directive. That means, in conformity with EU Directive Lead (Pb), Cadmium (Cd), Mercury (Hg), Hexavalent Chromium (Cr+6), Polybrominated Biphenyls (PBB) and Polybrominated Biphenyl Ethers (PBDE) have not been used except for exempted applications.

Compliance with environmental requirements

C&S Electric fully takes into account environmental requirements, starting right from the design phase of every product through to the end of its service life:

- the materials used for WiNmaster 2 are not potentially dangerous to the environment
- the production facilities are non-polluting in compliance with the ISO 14001 standard
- the energy dissipated per pole is low, making energy losses insignificant
- the materials are marked to facilitate sorting for recycling at the end of product service life.

Technical Characteristics

Characteristics as per IEC 60947-2 / Frame size

| Type | | | |
|----------------------------------------------------------|---------|----------------|--|
| Rated current (A) | In | at 50°C | |
| Rating of 4th pole (A) | | | |
| Number of poles | | | |
| Rated insulation voltage (V) | Ui | | |
| Impulse withstand voltage (kV) | Uimp | | |
| Rated operational voltage (V AC 50 Hz) | Ue | | |
| Suitability for isolation | | | |
| Degree of pollution | | | |
| Ultimate breaking capacity (kA rms) (V AC 50 Hz) | Icu | 415V - 50 Hz | |
| Rated service breaking capacity (kA rms) | Ics | 415V - 50 Hz | |
| Rated short-time withstand current (kA rms) (V AC 50 Hz) | Icw | 1s | |
| Rated making capacity (kA peak) (V AC 50 Hz) | Icm | 415 V AC | |
| Utilisation category | | | |
| Opening time (ms) | | | |
| Closing time (ms) | | | |
| Service life Mechanical | | with maint. | |
| | | without maint. | |
| Electrical | | without maint. | |
| Motor power | | VA | |
| Weight (kgs) | Fixed | 3Pole | |
| | | 4Pole | |
| | Drawout | 3Pole | |
| | | 4Pole | |
| Dimension (mm) (H x W x D) | Fixed | 3Pole | |
| | | 4Pole | |
| | Drawout | 3Pole | |
| | | 4Pole | |



| N Type | | | | | | | | H Type | | |
|-----------------|------|-------|-------|-------|-------|-------|-----------------|--------|-------|--|
| WX06 | WX08 | WX10 | WX12 | WX16 | WX20 | WX25 | WX20 | WX25 | Wx32 | |
| 630A | 800A | 1000A | 1250A | 1600A | 2000A | 2500A | 2000A | 2500A | 3200A | |
| 60% In/ 100% In | | | | | | | 60% In/ 100% In | | | |
| 3P, 4P | | | | | | | 3P, 4P | | | |
| 1000 | | | | | | | 1000 | | | |
| 12 | | | | | | | 12 | | | |
| 415 | | | | | | | 415 | | | |
| YES | | | | | | | Yes | | | |
| 3 | | | | | | | 3 | | | |
| 80 kA | | | | | | | 100 kA | | | |
| 50 kA | | | | | | | 65 kA | | | |
| 50kA | | | | | | | 65 kA | | | |
| 176 kA | | | | | | | 210 kA | | | |
| B | | | | | | | B | | | |
| 25 ms | | | | | | | 25 ms | | | |
| 40 ms | | | | | | | 40 ms | | | |
| 15000 | | | | | | | 15000 | | | |
| 6000 | | | | | | | 6000 | | | |
| 3000 | | | | | | | 3000 | | | |
| 85 | | | | | | | 110 | | | |
| 43 | 43 | 45 | 45 | 45 | 47 | 47 | 54 | 54 | 58 | |
| 52 | 52 | 54 | 54 | 54 | 56 | 56 | 64 | 64 | 69 | |
| 68 | 68 | 70 | 70 | 70 | 72 | 74 | 86 | 86 | 95 | |
| 77 | 77 | 80 | 80 | 80 | 81 | 83 | 104 | 104 | 115 | |
| 397x362x305 | | | | | | | 397x429x305 | | | |
| 397x457x305 | | | | | | | 397x544x305 | | | |
| 433x375x403 | | | | | | | 433x435x403 | | | |
| 433x470x403 | | | | | | | 433x550x403 | | | |



Cradle terminal as per panel manufacturer

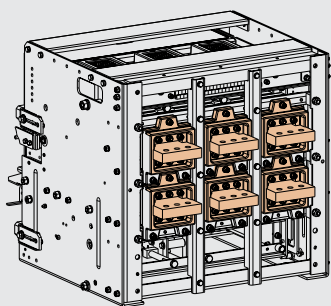

Horizontal type

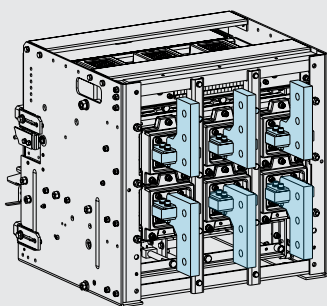

Vertical type

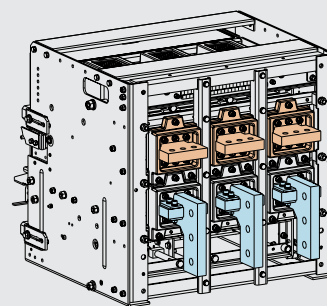

Mixed type

Connection installation

Connections for ease of different installation

C&S WiNmaster2 ACB meets your demands for high breaking capacity, fully line-up and optimized panel size. Various accessories and horizontal connection methods realize user friendly handling. This offers flexibility for construction of busbar as product is available with horizontal terminal requirement meeting varied customer requirement for termination. Such facility allows user to optimize the size of switchboards and busbar connection.

WiNmaster2 ACB provides you total solutions with an advanced trip relay for measurement, diagnosis, analysis and communication as well as protective functions for absolute protective co-ordination and electric power monitoring system.

Breaker connection in Horizontal Type

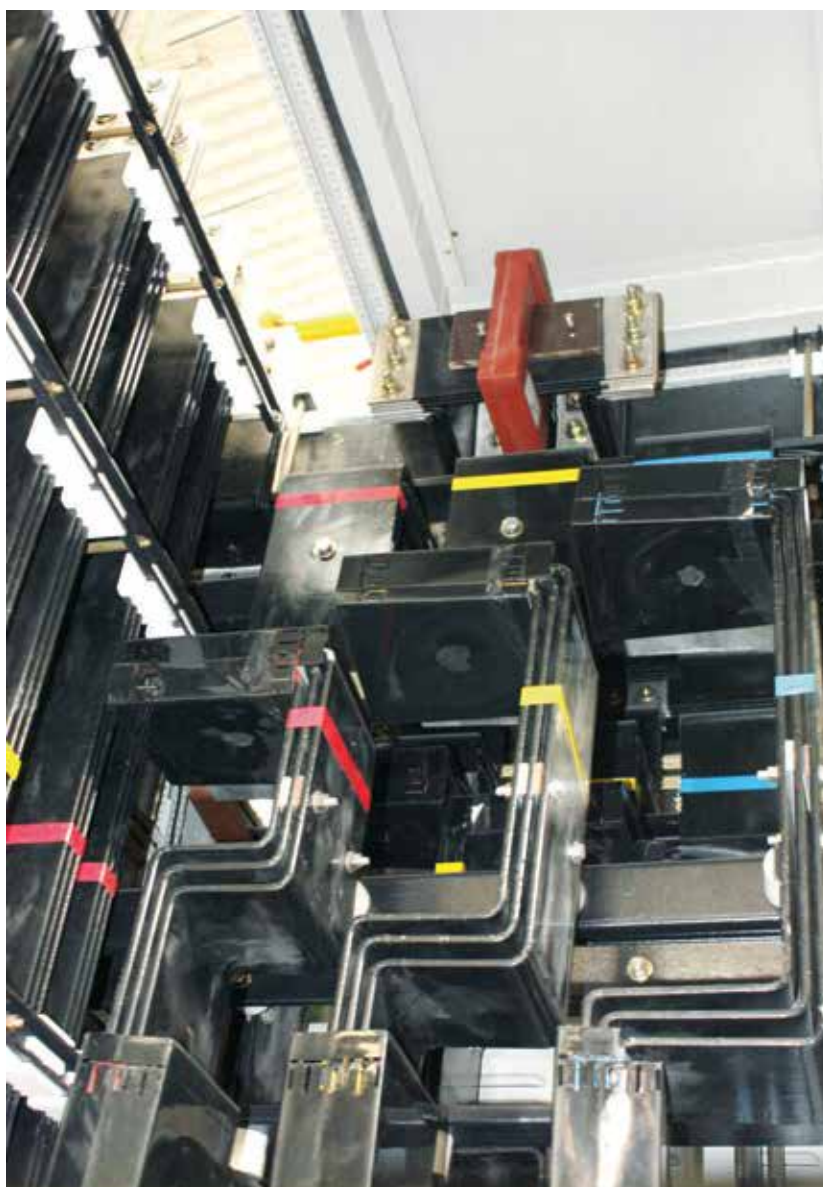

External configuration

- 1 Trip relay
- 2 ON button
- 3 OFF button
- 4 Operational position indication
- 5 Charge handle
- 6 Rated name plate
- 7 Charge/Discharge indicator
- 8 Front facia
- 9 Auxiliary terminal shield



Internal configuration

- 1 Auxiliary Contact group
- 2 Arc chute
- 3 Switch Body
- 4 Intelligent release
- 5 Spring charging motor
- 6 Electric motor
- 7 Charging handle
- 8 Closing coil
- 9 Shunt coil
- 10 UVT
- 11 UVT Delay block

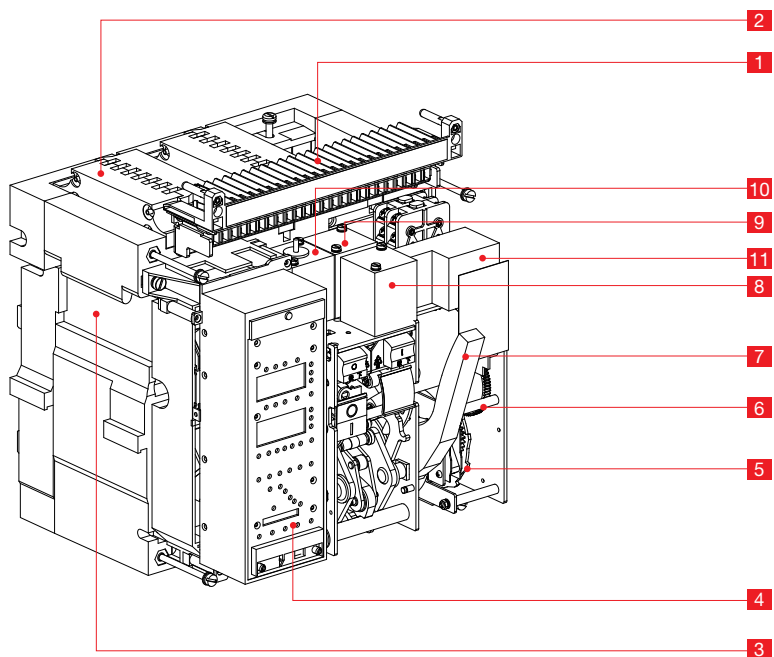

External configuration

Ease of Installation, Operation and Maintenance

All accessories are common for entire range and now can be easily fitted from the front.

Therefore, it is now possible to convert Manual breaker to electrical breaker at site or even in installation. All accessories (Shunt coil, UVT, closing coil, locks etc.) can now be installed very easily from front after removing the top cover of ACB and all accessories are clip-on require no screws for mounting and even motor drive require just one screw for mounting on the ACB for easy access.

- 1 Charging handle
- 2 Operational position indication
- 3 UVT Delay Block
- 4 Closing coil
- 5 Shunt coil
- 6 UVT coil
- 7 Spring Charging Motor
- 8 Pad Lock position
- 9 Auxiliary terminal shield
- 10 Auxiliary terminal

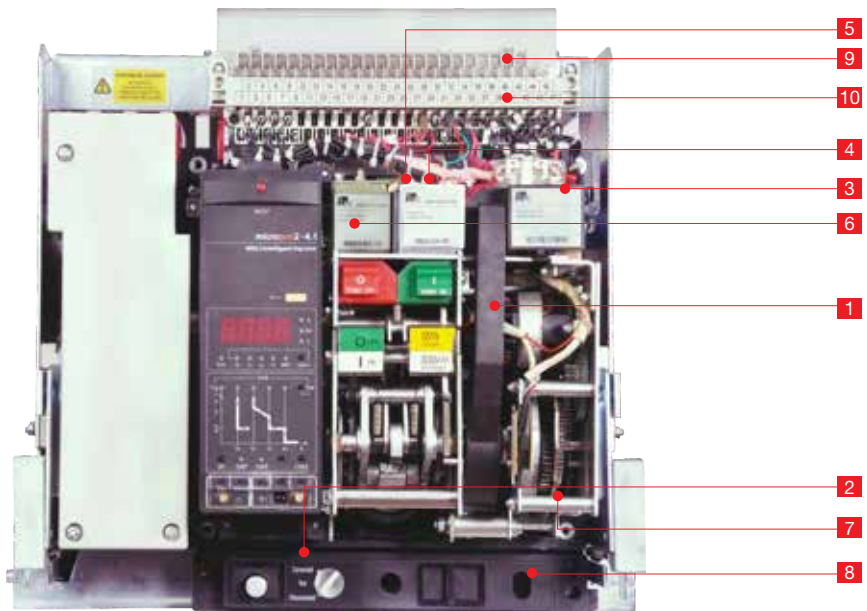



micropro2

quietly brilliant

The trip relay of WinMaster2 ACB provides the additional protection function for voltage, frequency unbalance and others in addition to main protection function for over current, short circuit, ground fault. It supports the advanced measurement functions for voltage, current, power, electric energy, harmonics, communication function and others

Analog trip function interlock with mechanism enhanced a durability of devices as well as the breaking capacity of ACB

Zone selective interlocking function make the protective coordination more simple and thermal memory can be applied to various loads

More options for different application and customer need

Today, Microprocessor based trip units has increased the scope of ACB function in any electrical system. With energy being the key both in terms of its availability and also conservation, it is required that energy is saved to its maximum optimizing its use to maximum when needed. Such complex present day requirement is easily achieved with use of sophisticated over current trip device fitted in ACB offering increasingly powerful functions. It offers measurement of system parameters, store data, log various events, calculate required data, signal alarms with communication through various modes and even take action to optimize the available energy in system etc. WiNmaster ACB equipped with Micro trip units offers both, reliable protection and accurate measurement.

Intelligent release overview

Base

The base, as a function actuating part, is composed of the following parts.

- Interlocking mechanism: when the actuator magnetic flux converter of release acts, it drives tripping lever to break the circuit breaker, keeps this position and let the circuit breaker be unable to close before resetting of interlocking mechanism.
- Resetting mechanism: it is a mechanical structure (reset button and its mechanism), after the magnetic flux converter operates and let the main contact open, this resetting mechanism can reset the magnetic flux converter.
- Magnetic flux converter: it produces a magnetic field after receiving the current from release circuit, to change the direction of magnetic line of force, it induces the movable iron core that is under the action of reaction spring to run, which drives the tripping lever to open the circuit breaker through interlocking mechanism.

Auxiliary contact of release

It determine the opening and closing position of two pairs of NO contacts according to the main contact state of circuit breaker. The other pair is of changeover contacts, determine its working position according to the state of magnetic flux converter

Body case

In the body case, there is a basic circuit board of release, which receives various signals and sends out various commands according to the preset functions and requirements after judgment, to finish the functions required by circuit breaker.

Sensor

The sensor is installed on the main circuit bus of circuit breaker, the neutral-line transformer may be installed separately at requests. The sensor provides the energy and signal for the release. This sensor is different from the traditional transformer, it is made up of a rapidly saturable current transformer that is used to provide the normal work energy for release and an air-core transformer that is used to provide current for circuit. Magnitude of secondary current of air-core transformer is directly proportional to that of main circuit current. These two transformers are installed in a round plastic box together.

Power supply accessories

There are many kinds of power supply accessories: the one installed on the base is used for release display and working state memory when the main circuit of circuit breaker opens or current is very weak; power supply accessories installed on the drawer seat include AC power supply, DC power supply, uninterruptible (battery) power supply and so on (used for full-intelligent type release), to guarantee the power supply for release and relay accessories.

Relay

The relay, as a function extension of release, can be divided into two types: one is used to provide overload and short-circuit operation indication, load monitoring operation command and indication, earthing fault indication, local fault indication and so on totally sixteen types of relay contact output with different combinations for user according to the command of release. The other one is under control of computer, transmits various parameters remotely and relay output providing various indications and operations with different combinations for user.

Intelligent trip units

Micropro release is equipped with LCD display which is part of same navigator panel. Control unit is designed to offer great use for user to access and operate the same easily and without any training.

Micropro is completely microprocessor based device with LCD display offering various options including ammeter, power measurement, zone selectivity, Neutral protection, diagnosis facilities and harmonics filter. These control units also offers communication through RS485 / Modbus protocol.

Features

- Release Type MicroPro2-3.1, 4.1 & 7.1
- LSIGN with additional protection - under Current, Current unbalance under / over voltage, under/over Current, under/over Frequency & Earth Leakage
- Measurement of True RMS value of current
- Measurement of Current, Voltage, Frequency, Harmonics & Power parameters and also store max. value in maximeter
- Last fault Trip history
- Zone selective interlocking
- Digital display & fault LED retention
- Zone selective interlocking
- In-built thermal memory
- 1 or 2 way communication
- Communication Protocol through Modbus-RS 485/232



MicroPro2-3.1



MicroPro2-4.1



MicroPro2-7.1

Intelligent trip units

MicroPro2 3.1

- Overload protection
- Short Circuit current protection
- Earth Fault protection
- INST Fault protection

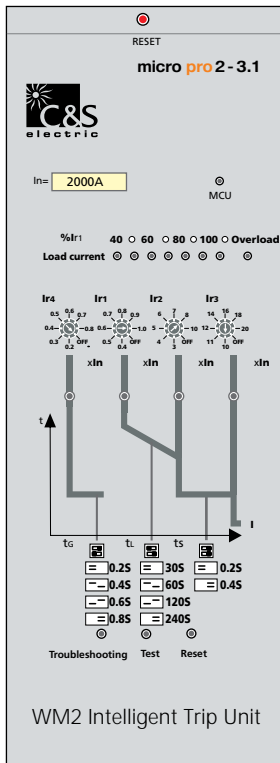

MicroPro2 4.1

- Overload & Short Circuit protection
- Instantaneous current protection
- Neutral & Ground Fault Protection
- Ampere Meter
- Digital display and fault LED retention in case of power failure

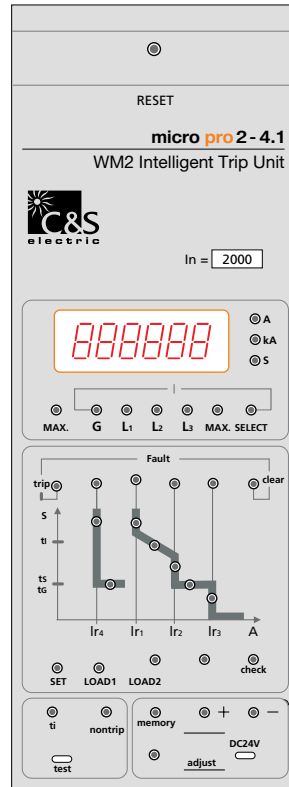

MicroPro2 7.1

- Overload & Short Circuit protection
- Instantaneous current protection
- Neutral & Ground Fault / Leakage Protection
- Various Protection related to voltage, frequency, load and motor
- Zone Selectivity, Measurement of V, I, P, F, KWH, KVArh, Harmonics etc. and also store the maximum value in maximeter

Communication

- Port: RS485
- Protocol: Modbus/Profibus/Devicenet

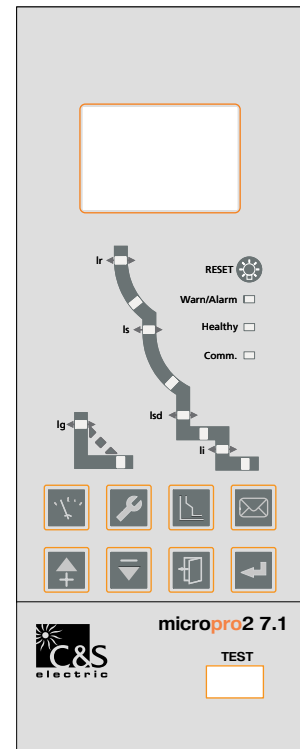

Micropro 2 - 7.1

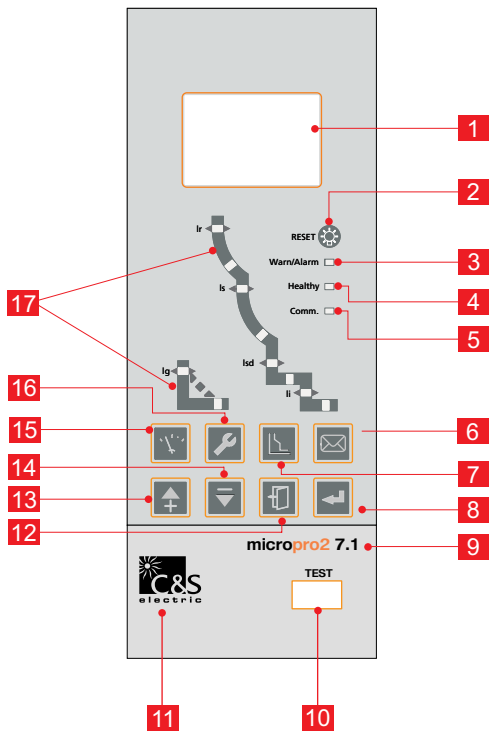

- 1 LCD display
- 2 Reset key
- 3 Warn / alarm LED
- 4 Healthy LED
- 5 Communication Indication
- 6 Information Key
- 7 Protection setting Key
- 8 Enter Key
- 9 Series name
- 10 Test port
- 11 Corporation Logo
- 12 Exit Key
- 13 Upward Key
- 14 Downward Key
- 15 Measure Key
- 16 Basic setting Key
- 17 Tripping characteristics curve

Protection settings

Protection thresholds and delays are set using the keypad buttons or the communication software. The selected values are momentarily displayed on the display.

Overload protection

- True RMS long-time protection
- Multiple ranges of Protection Curves for the co-ordination from inductive load to high voltage fuse: SI, VI, EI (G), EI (M), HV, and I2T.
- Multiple selection of Thermal memory: thermal image before & after tripping.
- The long-time setting "OFF" enables to cancel the overload protection.

Short-circuit protection

- Short-time (RMS) and instantaneous protection.
- Selection of Fixed Time Delay & Inverse Trip Current type, (ON or OFF) for delay.
- Zone Selectivity Interlock.

Neutral protection

In Practice, cable & current characteristics of the neutral phase is very different from that of the other three phases. Micropro 2 7.1 take different protection measures according to different application needs. When the cable is relatively thin, half the set value can be used, and when the cable is normal, the set value can be used. When the mains harmonics are relatively big, double value.

Earth fault protection

- Earth fault protection is definite type curve setting, which ensure the more reliability
- Setting "OFF" enables, to cancel the earth fault protection
- Earth fault Zone selective Interlocking

Earth Leakage Protection

This function is to prevent the leakage damage caused by insulation failure of the equipment. The unit of the tripping value is ampere and is irrelevant with the rated current of breaker. For Zero sequence signals adapting a rectangle mutual inductor is needed for better precision and sensitivity in the protection of small current.

Additional Protection & Alarm

The Micropro 2 7.1 can be set for the Air Circuit Breaker tripping provides the protection against the following parameters.

- Over & under voltage
- Voltage Unbalance
- Over & Under frequency
- Current unbalance
- Reverse Power
- Phase sequence
- Maximum required value protection

Micropro 2 - 7.1



Measurement

- Micropro displays the electrical parameter like Current values, instant current value (RMS) including ground fault current, Creepage current with measuring precision of 5% (at above In) & 1.5% (at 2In) and also store the maximum value in maximeter.
- Phase to phase & phase to neutral Voltage measurement with 0.5% precision and also store the maximum value in maximeter.
- Phase sequence
- Phase Unbalance
- Active Power, Reactive Power & Apparent power and also store the maximum value in maximeter.
- Power factor
- Electrical Energy
- Calculation of current and voltage total harmonic distortion (THD)
- Current and voltage and power fundamentals
- Current and voltage harmonics up to the 31st order

Communication option

Micropro2 7.1 can be connected with the protocol with the help of Rs 485/232 to converter. Communication gives facility to perform following action:

- To read & set all functions parameters remotely
- To transmit all the measurements
- To give signals for the tripping & alarms
- To give maintenance history (Number of operation & contacts wear % etc)
- An event log and a maintenance register, stored in Micropro2 7.1 memory are also available locally.
- The voltage & current waveform can be captured to analyze the power quality waveform

Histories

The last 8 trips, alarms & ACB status are recorded in to 3 separate files that may be displayed on screen.

- **Tripping history**
 - Type of fault
 - Date & time
 - Values measured at the time of tripping
- **Alarm histories**
 - Type of fault
 - Date & time
 - Values measured at the time of alarm
- **ACB status**
 - It will give information about the ACB tripping locally or remotely etc.

Maintenance indicators

Micropro2 7.1 gives information about the maintenance parameters of ACB.

- Total no of mechanical operation counter.
- Contact wear

MCR & HSISC Protection

MCR & HSISC is the instantaneous protection of the breaker itself. When limit exceeding fault current is detected, the breaker will send out a trip command within 10ms. MCR protects the making capacity of the breaker and prevents switch damage caused by making current exceeding the making capacity. The protection is enabled instantaneously (within 100ms) after closing and opening. HSISC is a breaker protection which prevents the breaker from carrying a persistent through fault current greater than it's through fault capability. It is effective after 100ms after breaker closing. Micropro2 7.1 can do the analysis of power quality including calculation of harmonics and the fundamentals. Voltage & current Wave form can be analyzed for any event in power supply system. It gives an enhanced alarm programming to analyze and track down the disturbance in the power network system.

Micropro 2 - 7.1



| | |
|--------------------------------------------|--------------------------------------------------------------------------------------------------------------|
| Over Load Protection | |
| Pick up | Off 0.4 ~ 1.0In |
| Protection Curve | SI, VI, EI(G), EI(M), HV, I2T |
| Thermal Memory | Instantaneous, 10 m, 20m, 30m, 45m, 1h, 2h, 3h |
| Delay | C 01 ~ C16 (rated at 1.5, 6 & 7 Ir) |
| Short Circuit | |
| Pick up | Inverse Trip Current Is = Off +1.5 ~ 15Ir |
| | Fixed Time Trip Current Is = Off +1.5 ~ 15Ir |
| Fixed Time Delay Time Tsd | 0.1 ~ 0.4 S |
| Zone Selectivity Interlock | Available |
| Instantaneous | |
| | OFF+1.0~20In |
| N Protection | |
| Pick up | 50%, 100%, 160%, 200%, Off |
| Earth Fault | |
| Earth Fault Protection | OFF+0.2~1.0xIn |
| Inverse Curve Multiple Cr | 1.5~6, +OFF, |
| Delay Tg | 0.1~1S, |
| Earth Fault Zone Selective Interlocking | Available |
| Earth Leakage | |
| Earth Leakage Protection Δn | 0.5~30.0A |
| Delay Time T Δn (S) | Instantaneous, 0.06, 0.08, 0.17, 0.25 0.33, 0.42, 0.5, 0.58, 0.67, 0.75, 0.83 |
| Current Unbalance Protection | 5%~60% |
| Delay Set Value | 0.1~40.0S |
| Return Value | 5%~Start Value |
| Return Delay | 10~200S |
| Performance | Alarm/Break/Close |
| Under Voltage Protection Parameters | |
| Protection Start Set Value | 100V~Return Value |
| Protection Delay Set value | 0.2~60S |
| Protection Return Value | Start Value~1200V |
| Protection Delay Return Time | 0.2~60S |
| Protection Alarm DO Output | Set one of the DO of the signal unit as "Under Voltage Alarm". Protection Performance Alarm/Break/Switch Off |

Micropro 2 - 7.1



Over Voltage Protection Parameters

| | |
|----------------------------------------------|----------------------------------------------------------------------------------------------------------------------------------------------------------------------------------------------------------|
| Set value of the protected Starting | Return value~1200V |
| Delay time set of the protected operation | 0.2~60S |
| Set value of the protected operation returns | Start Value ~1200V |
| Delay time of protection returns | 0.2~60S |
| Protect alarming DO output | Set one DO of the signal units as“overvoltage error”. (not muST, if not set this item, the alarm information will only be read from the screen of the controller, without the connecting point output;) |
| Protection operating way | alarm/trip/close |

Voltage Unbalance Protection

| | |
|-------------------------------------------------|------------------------------------------------------------------------------------------------------------------------------------------------------------------------------------------|
| set value of the Protected Start | 2%-30% |
| Set value of the protected operation delay time | 0.2-60.0S |
| Return set value of the protected operation | 2%~ Starting value |
| Delay time of the protected return | 0.2-60.0S |
| Protected alarm DO output | Set one DO of the signal units “U imbalance alarm”. (not muST, if not set this item, alarm infor can only be read from the screen of the controller, without the connecting port output) |
| Performing way | Alarm/trip/close |

Underfrequency Protection Parameters

| | |
|-------------------------------------------------|-------------------------------------------------------------------------------------------------------------------------------------------------------------------------------------------------|
| Set value of the Protected Start | 45.0~ return value |
| Set value of the protected operation delay time | 0.2~5.0S |
| Return set value of the protected operation | Start value~65Hz |
| Delay time of the protected return | 0.2~36.0S |
| Protected alarm DO output | Set one DO of the signal units as“underfrequency error”. (not muST, if not set this item, the alarm infor can be only read from the screen of the controller, without connecting port output;) |
| Performing way | Alarm/trip/close |

Over frequency Protection Parameters

| | |
|-------------------------------------------------|--------------------------------------------------------------------------------------------------------------------------------------------------------------------------------------------------|
| Set value of the Protected Start | Return value~65.0HZ |
| Set value of the protected operation delay time | 0.2~5.0S |
| Return set value of the protected operation | 45.0HZ ~Start value |
| Delay time of the protected return | 0.2~36.0S |
| Protected alarm DO output | Set one DO of the signal units as“overfrequency error”. (not m muST, if not set this item, the alarm infor can be only read from the screen of the controller, without connecting port output;) |
| Performing way | Alarm/trip/close |

Micropro 2 - 7.1



| Reverse Power Protection | |
|-------------------------------------------------|----------------------------------------------------------------------------------------------------------------------------------------------------------------------------------------------------|
| Set value of the Protected Start | 5~500kW |
| Set value of the protected operation delay time | 0.2~20S |
| Return set value of the protected operation | 5 kW~Start value |
| Delay time of the protected return | 1.0~360S |
| Protected alarm DO output | Set one DO of the signal units as "power error". (not m muST, if not set this item, the alarm infor can be only read from the screen of the controller, without connecting port output;) |
| Performing way | Alarm/trip/close |
| Phase sequence protection | |
| Operating phase sequence | □□: A, B, C / □□: A, C, B |
| Protected alarm DO output | Set one DO of the signal units as "phase sequence error". (not m muST, if not set this item, the alarm infor can be only read from the screen of the controller, without connecting port output;) |
| Performing way | Alarm/trip/close |
| Leakage Alarm | |
| Current Setting of Alarm Action | 0.5~30.0A |
| Alarm Action Time Delay | 0.0~1.0S |
| Alarm Return Current Setting | 0.5~30.0A |
| Alarm Return Delay | 0.0~1.0S |
| Alarm DO Output | Set one DO of the signal unit as "Leakage Alarm". |
| Performance | Alarm + Switch Off |
| Current Unbalance Protection | |
| Delay Set Value | 0. 1~40.0S |
| Return Value | 5%~Start Value |
| Return Delay | 10~200S |
| Alarm DO Output | Set one of the DO of the signal unit as "I unbalance alarm". |
| Performance | Alarm/Break/Close |
| Indication | |
| Power ON LED | Available |
| Over Load Flashing LED | Available |
| OL/ SC/ EF Trip LED | Available |
| LCD Display | Available |
| Protocol | |
| Modbus | |
| Converter | RS485/232 |

Micropro 2 - 4.1

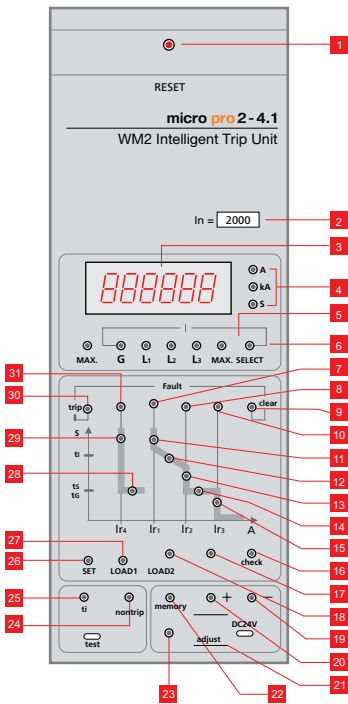

Protection settings

Protection thresholds and delays are set using the adjustment dip switches. The running load is displayed in amperes

Overload protection

True RMS long time protection.
Thermal memory: thermal image before and after tripping.
The long time setting "OFF" enable to cancel the overload protection

Short circuit protection

Short time (RMS) and instantaneous protection

Earth fault protection

Earth fault protection is definite type curve setting, which ensure the more reliability

Last fault tripping history

On digital display last fault history can be viewed.

- 28 Grounding protection time setting and alarm indicator
- 29 Grounding protection current setting and alarm indicator
- 30 Fault trip indicator
- 31 Grounding protection fault indicator
- 32 Test action indicator

- 1 Reset button
- 2 Rated current label
- 3 Current display
- 4 Current and time units
- 5 Phase ground & the maximum phase current
- 6 Current view selection key
- 7 Overload fault trip indicator
- 8 Short circuit fault trip delay indicator
- 9 Clear reset button
- 10 Short current instantaneous fault trip indicator
- 11 Long delay overload current protection setting and alarm button
- 12 Overload protection long delay time setting indicator
- 13 Short circuit current of the short time delay
- 14 Short circuit protection short delay time setting indicator
- 15 Short circuit current instantaneous protection and alarm indicator
- 16 Troubleshooting button
- 17 Spare key
- 18 Load monitoring and alarm indicator 2 current set
- 19 Set the value of the reduced bond
- 20 Set the value of the increased bond
- 21 Panel power jack
- 22 Setting storage switch
- 23 Storage indicator
- 24 Do not trip test button
- 25 Trip test button
- 26 Parameter setting selection key
- 27 Load monitoring a current setting and alarm indicator

Micropro 2 - 4.1



Over Load Protection

Current Setting (A) $I_r = I_n \times$ 0.4 1, OFF

Tripping between 1.05 and 1.2 x I_r

| | | | | | | | |
|----------------|------------|------|------|------|------|------|------|
| Time setting | tr (s) | 15 | 30 | 60 | 120 | 240 | OFF |
| Time delay (s) | 1.5x I_r | 15 | 30 | 60 | 120 | 240 | 480 |
| | 2x I_r | 8.4 | 16.9 | 33.8 | 67.5 | 135 | 270 |
| | 7.2x I_r | 0.65 | 1.3 | 2.6 | 5.2 | 10.4 | 20.8 |

Thermal memory 300 min
Output DO single alarm Available

Short time I_{sd}

Pick-up (A) $I_{sd} = I_r \times$ 0.4 15, OFF

| | | | | | |
|-------------------------------------|-------------------------|---------------------------------------|-----|-----|-----|
| Time setting | tsd (s) | 0.1 | 0.2 | 0.3 | 0.4 |
| Time delay (ms) Accuracy \pm 40ms | I^2t on $I > 8I_r$ | 100 | 200 | 300 | 400 |
| | I^2t on $I \leq 8I_r$ | $t = \frac{(8I_r)^2}{I^2} \times tsd$ | | | |

Instantaneous I_i

Pick-up (A) $I_i = I_n \times$ 1 50kA, OFF

Time setting Instantaneous

Earth fault I_g

Pick-up (A) $I_g = I_n \times$ 0.2 1, OFF

| | | | | | |
|-------------------------------------|-----------|-----|-----|-----|-----|
| Time setting | tg (s) | 0.1 | 0.2 | 0.4 | OFF |
| Time delay (ms) Accuracy \pm 40ms | tg (s) | 0.1 | 0.2 | 0.3 | 0.4 |
| | Min. (ms) | 60 | 160 | 255 | 340 |
| | Max. (ms) | 140 | 240 | 345 | 460 |

Indication, Monitoring & Control

- Power On Led indicator
 - Overload LED indicator
 - Overload trip LED indicator
 - Short circuit trip LED indicator
 - Earth fault trip LED indicator
 - Trip history
 - Thresholds and delay setting by dip switches
 - Test function
 - Load monitoring
- (Earlier terminology Long time I_{r1} , Short Time I_{r2} , Instantaneous I_{r3} , Earth fault I_{r4})

Micropro 2 - 3.1

Micropro2-3.1 type relay is pull switch coding switch and tuning method is simple, easy and intuitive.

Protection settings

Protection thresholds and delays are set using adjustable coding switch

Overload protection

True RMS long time protection with adjustable threshold setting

Short circuit protection

Short time (RMS) protection with adjustable threshold setting

Earth fault protection

True RMS earth fault protection with adjustable threshold and delay settings

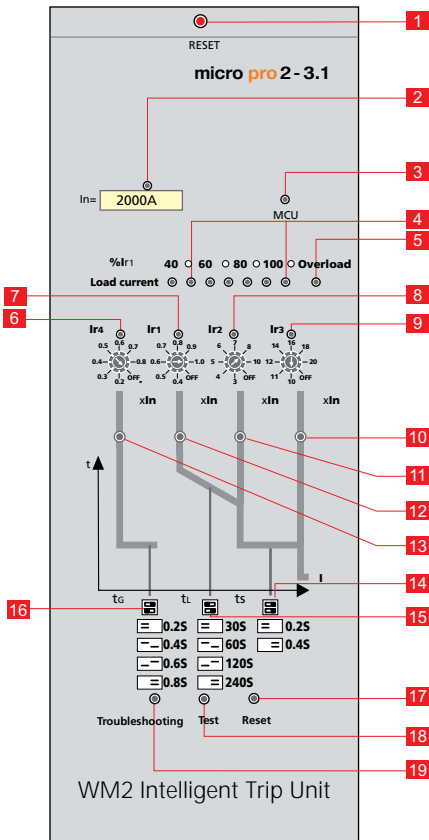

- 1 Reset button
- 2 Rated current value
- 3 Power ON button
- 4 Current beam for long time
- 5 Overload indicator
- 6 Grounding protection current setting coding switch
- 7 Overload protection long delay current setting switch
- 8 Short circuit current of the short time delay setting coding switch
- 9 Short circuit current coding switch transient protection
- 10 Short circuit transient protection fault indicator
- 11 Short time delay short circuit fault indicator
- 12 Long delay overload protection fault indicator
- 13 Grounding protection fault indicator
- 14 Short circuit protection short delay time stubbs switch setting
- 15 Overload protection long delay time setting slide switch
- 16 Grounding protection time setting slide switch
- 17 Reset button
- 18 Test release button
- 19 Troubleshooting button

Micropro 2 - 3.1



Over Load Protection

Current Setting (A) $I_r = I_n \times$ 0.4, 0.5, 0.6, 0.7, 0.8, 0.9, 1 OFF

Tripping between 1.05 and 1.2 x I_r

| | | | | | |
|----------------|-------------|------|------|------|------|
| Time setting | tg (s) | 30 | 60 | 120 | 240 |
| Time delay (s) | 1.5 x I_r | 30 | 60 | 120 | 240 |
| | 2 x I_r | 16.9 | 33.8 | 67.5 | 135 |
| | 7.2 x I_r | 1.3 | 2.6 | 5.2 | 10.4 |

Thermal memory 30 min
Output DO single alarm Optional

Short time I_{sd}

Pick-up (A) $I_{sd} = I_r \times$ 3, 4, 5, 6, 7, 8, 10, OFF
Time setting t_{sd} (s) 0.2, 0.4
constant time-lag

Instantaneous I_i

Pick-up (A) $I_i = I_n \times$ 10, 11, 12, 14, 16, 18, 20, OFF
Time delay (s) Instantaneous

Earth fault I_g

Pick-up (A) $I_g = I_n \times$ 0.2, 0.3, 0.4, 0.5, 0.6, 0.7, 0.8, OFF
Time delay (s)

| | | | | |
|-----------|-----|-----|-----|-----|
| tg (s) | 0.2 | 0.4 | 0.6 | 0.8 |
| Min. (ms) | 160 | 340 | 510 | 680 |
| Max. (ms) | 240 | 460 | 690 | 920 |

constant time-lag

Indication, Monitoring & Control

- Power On Led Indicator
- Overload LED indicator
- Overload trip LED indicator
- Short circuit trip LED indicator
- Earth Fault trip LED indicator

(Earlier terminology Long time I_{r1} , Short Time I_{r2} , Instantaneous I_{r3} , Earth fault I_{r4})

N

RESET

micropro2-4.1
WM2 Intelligent Trip Unit

In = 2500A

● A
● KA
● S

Test G L1 L2 L3 MAX Select

Fault Clear

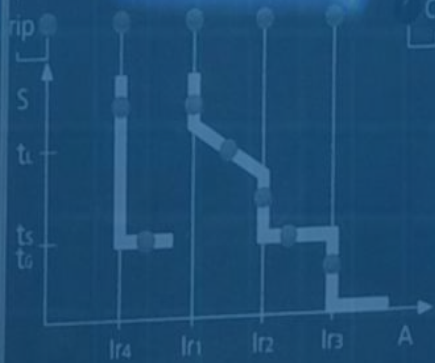

Set Load1 Load2 Check

Test Adjust

Micropro 2 - 3.1

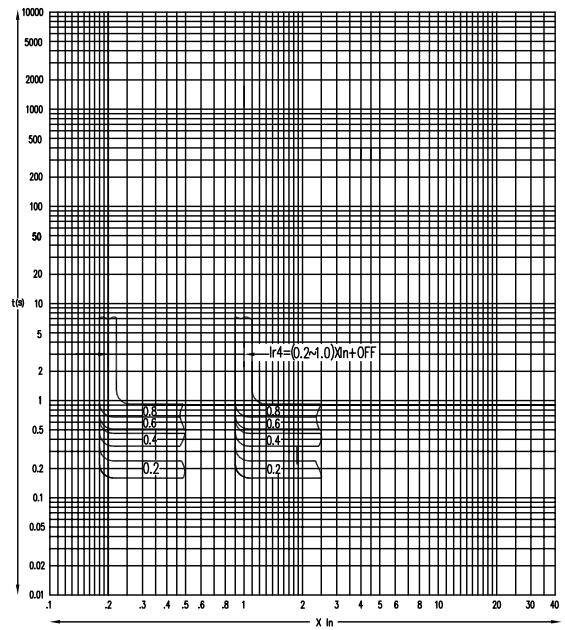
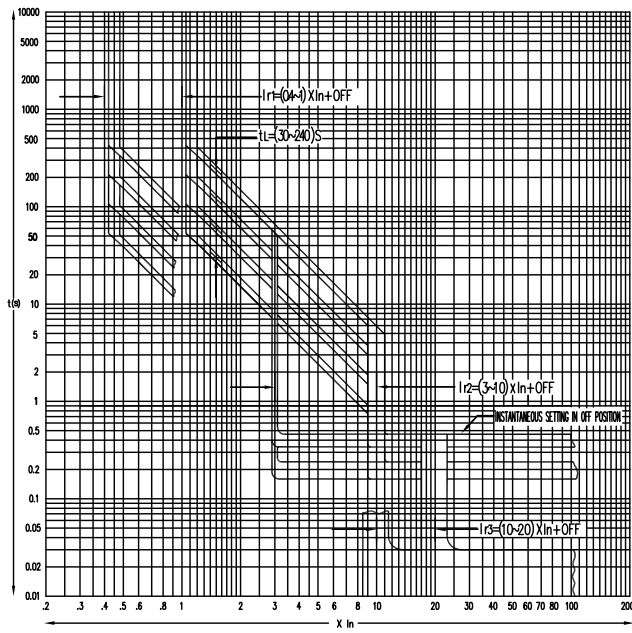

Micropro 2 - 4.1

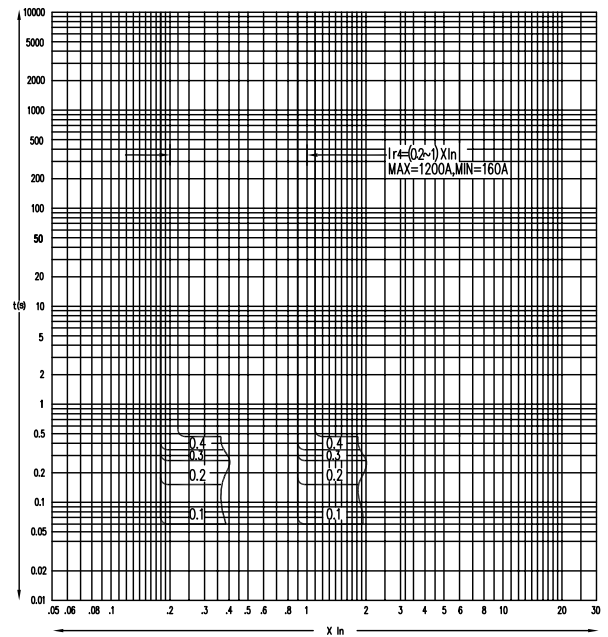
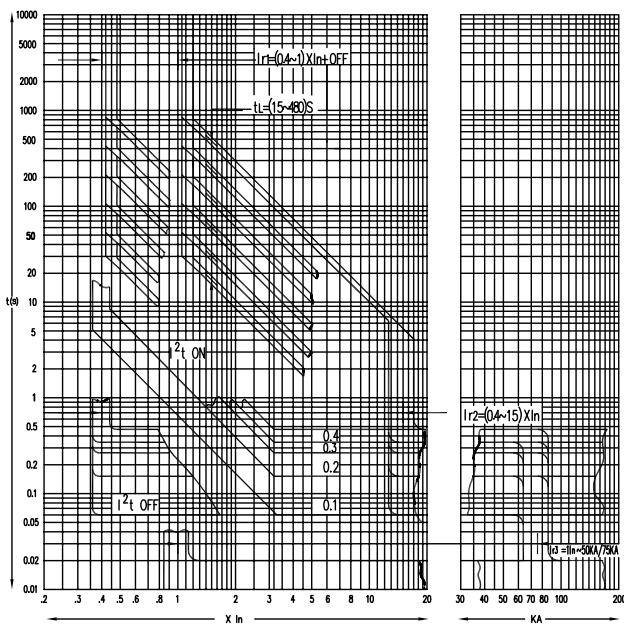

Characteristics Curve

Micropro 2 - 7.1

Chart A2
Standard inverse time lag

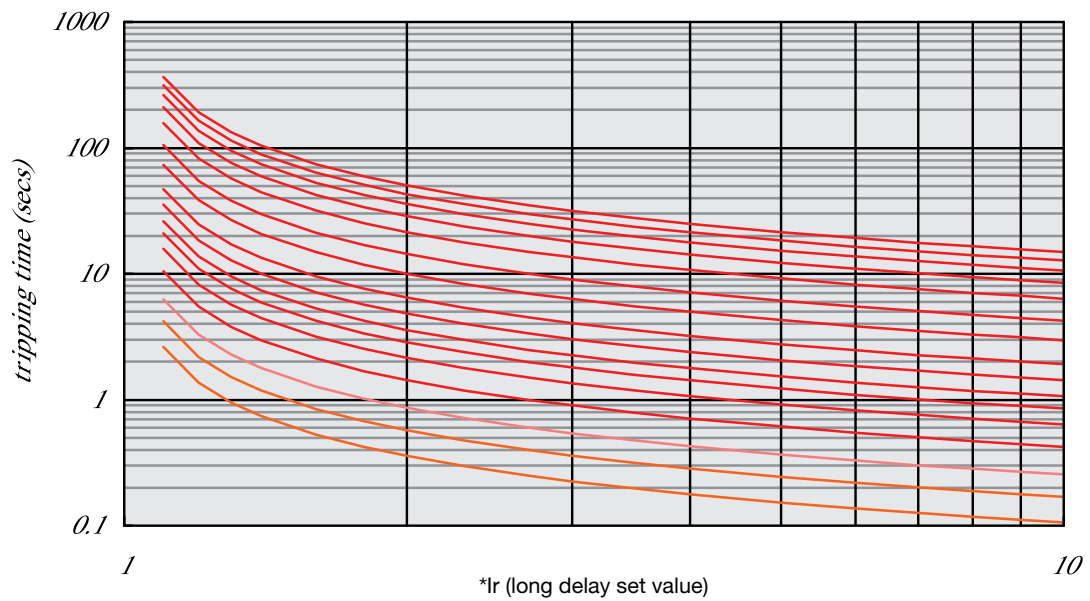
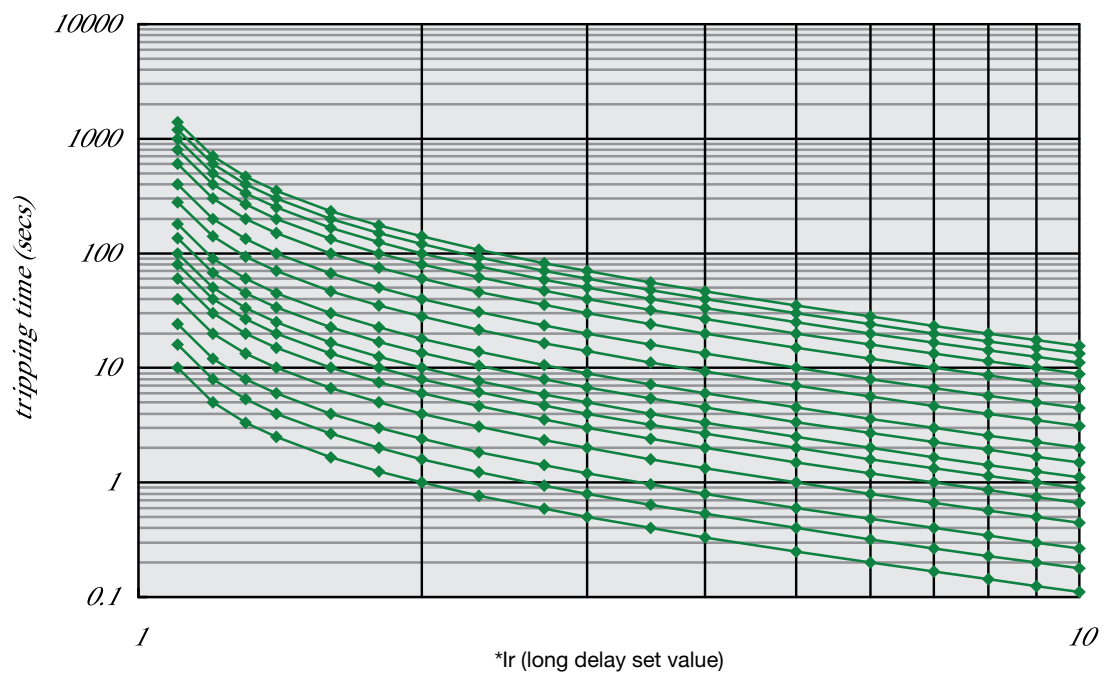

Chart A3
Very inverse time lag



Characteristics Curve

Micropro 2 - 7.1

Chart A4
Extremely inverse time lag (distributing protection)

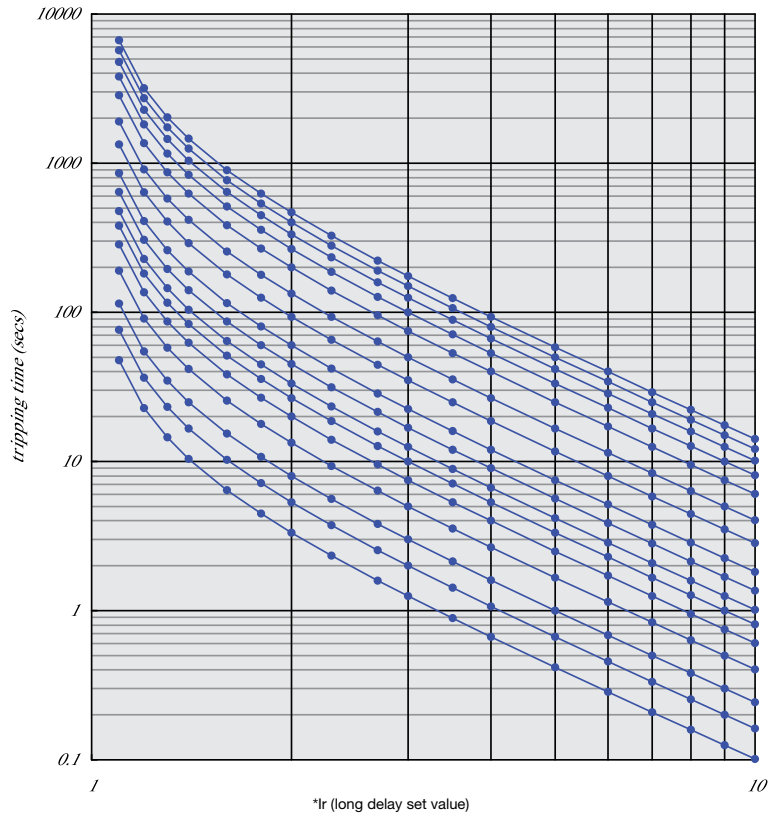
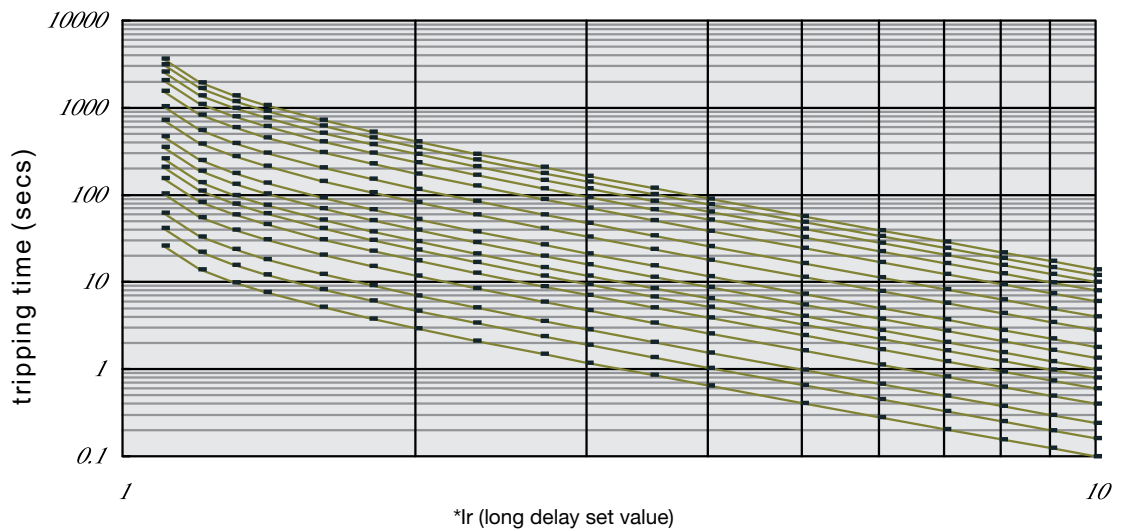

Chart A5
Extremely inverse time lag (generator protection)



Characteristics Curve

Micropro 2 - 7.1

Chart A6
High voltage fuse compatible

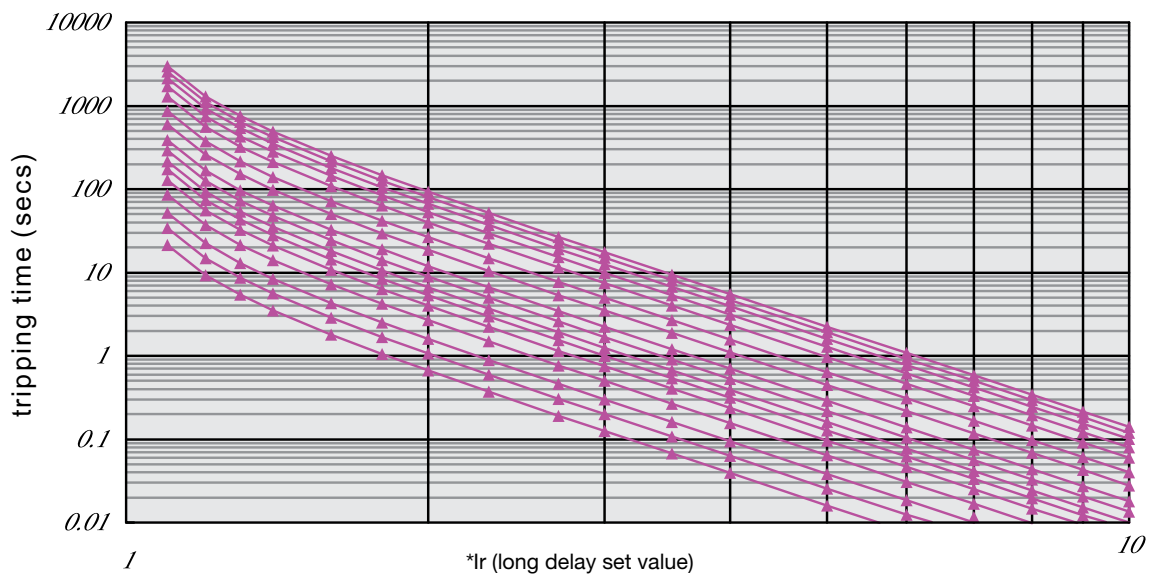
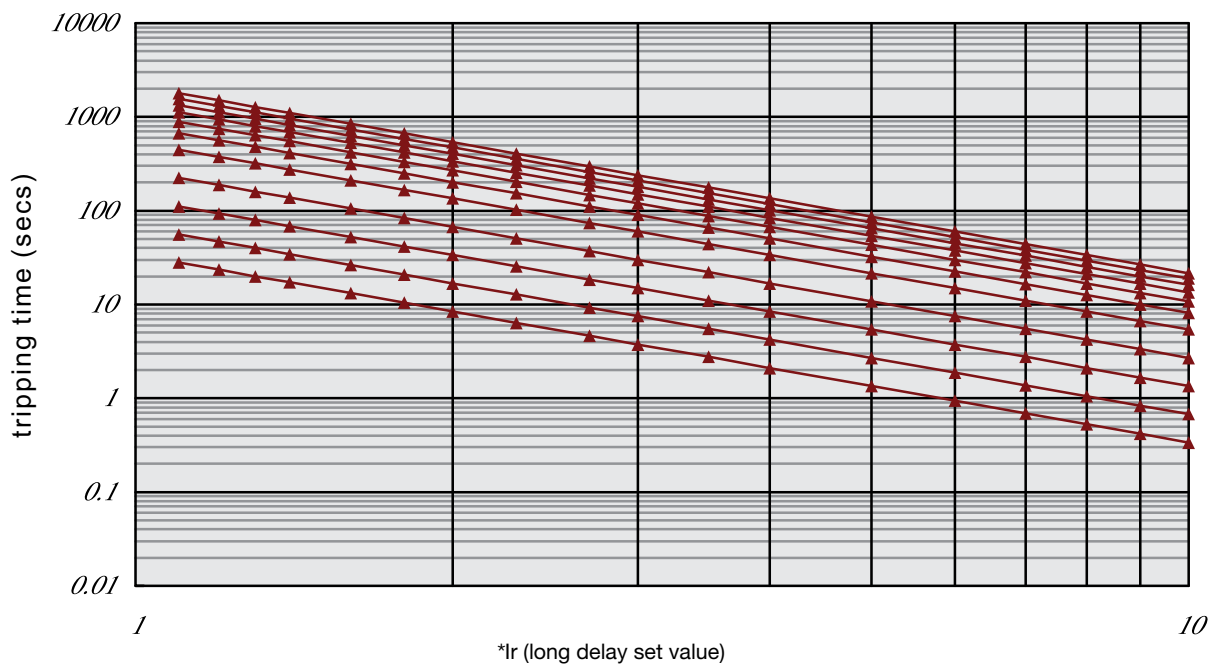

Chart A7
Extreme inverse time curve



Characteristics Curve

Micropro 2 - 7.1

Chart S1

Short delay reverse time lag - standard reverse time lag

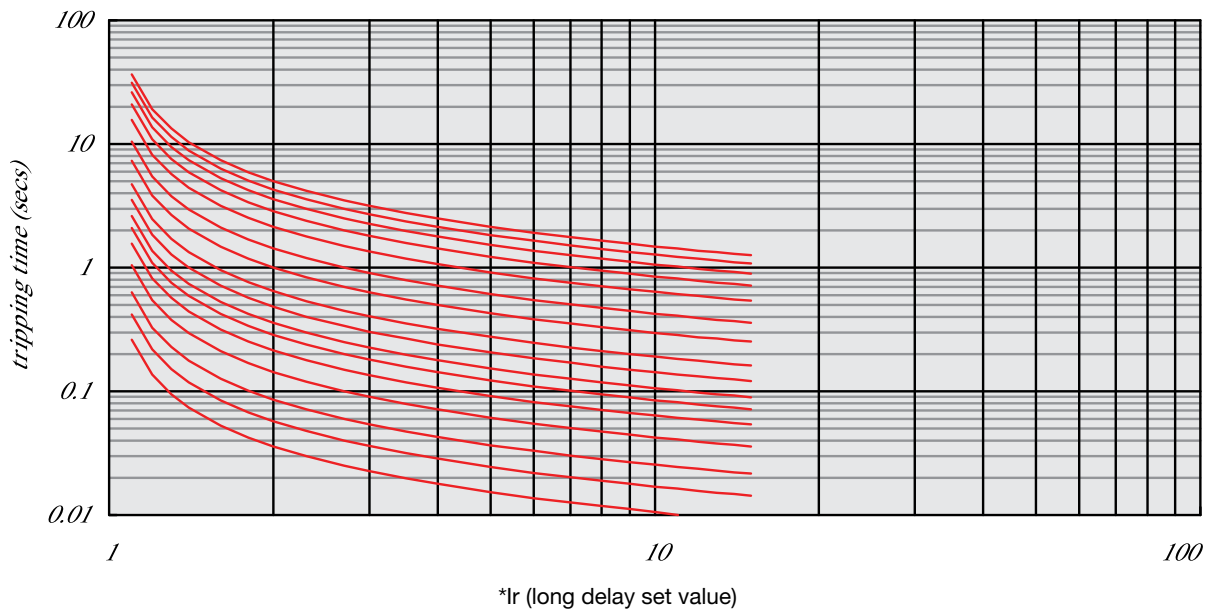
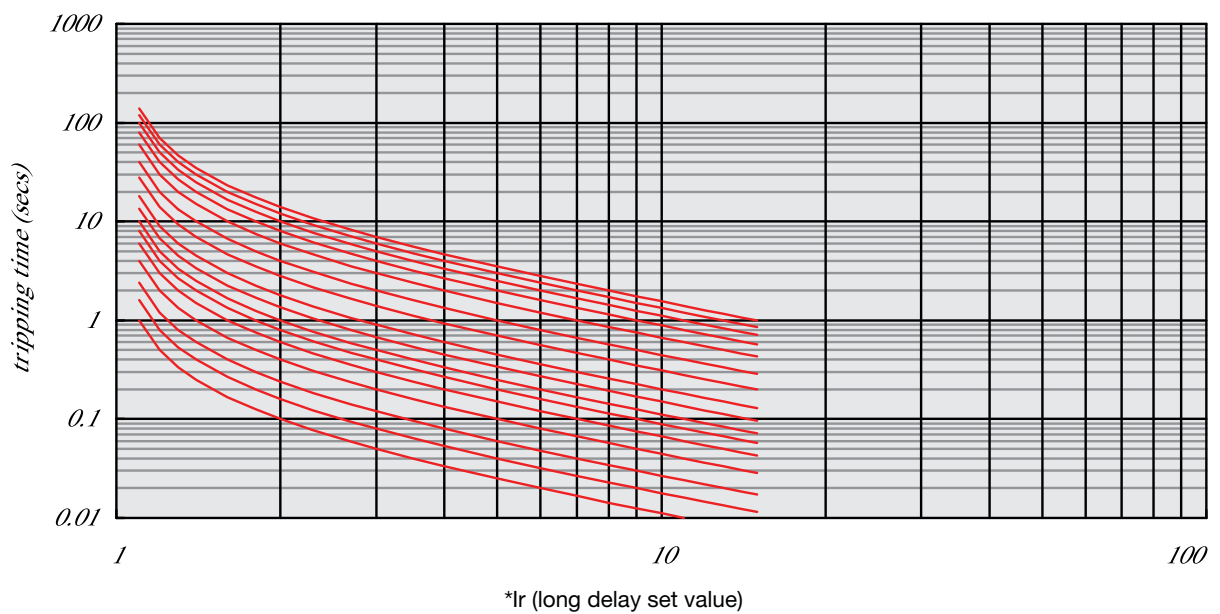

Chart S2

Sort time delay reverse time lag - fast reverse time lag



Micropro 2 - 7.1

Chart S3

Short delay reverse time lag - express reverse time lag
(distributing protection)

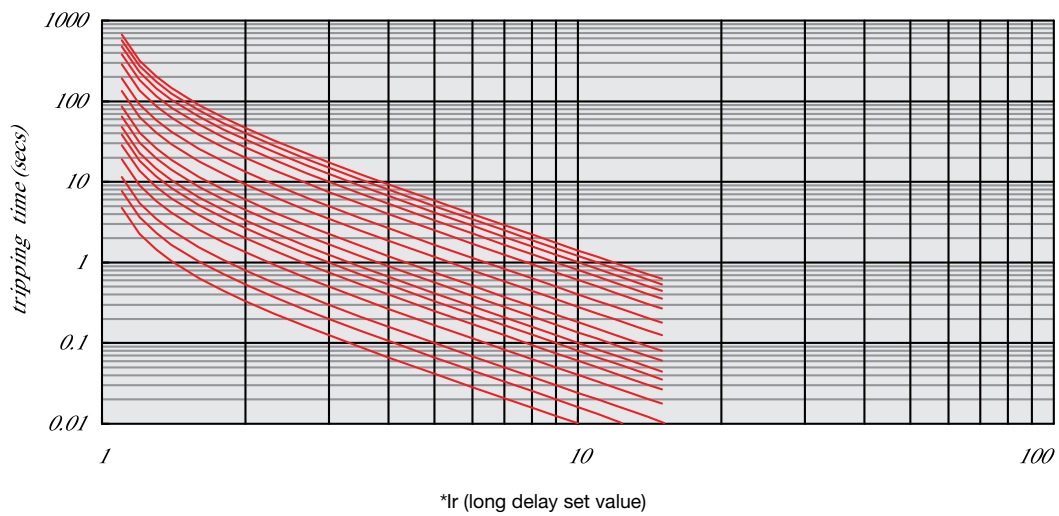
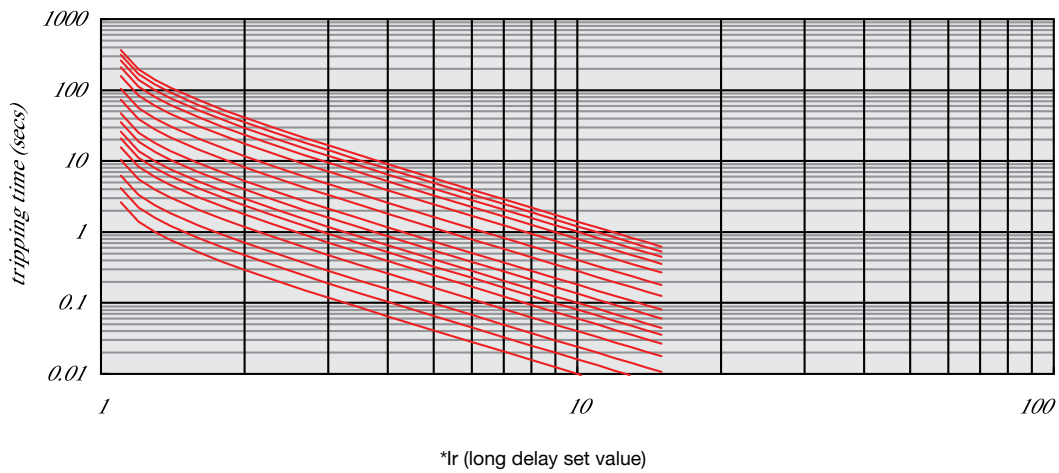

Chart S4

Sort delay reverse time lag - express reverse time lag
(generator protection)



Characteristics Curve

Micropro 2 - 7.1

Chart S5

Short delay reverse time lag - high voltage fuse compatible

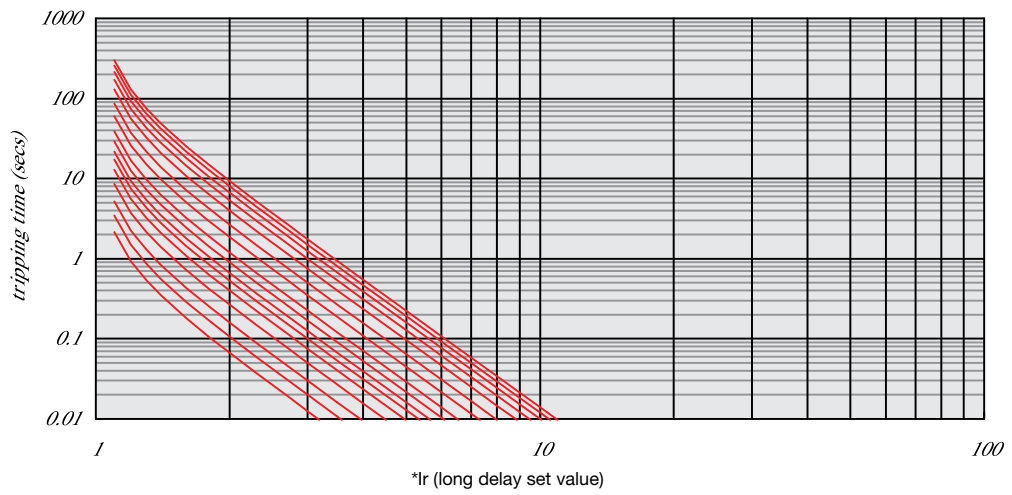
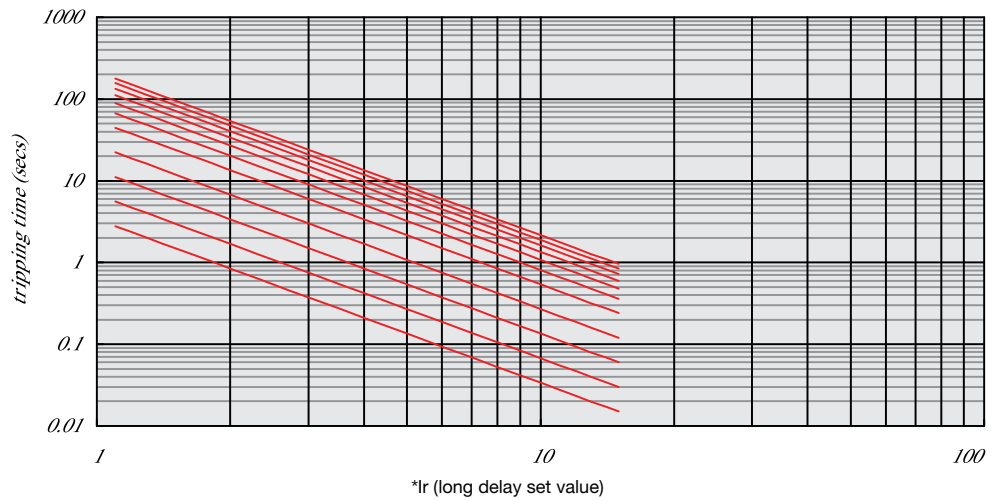

Chart S6

Short time reverse time lag - common use reverse time lag



Characteristics Curve

Micropro 2 - 7.1

Chart C1
Protection example of reverse time lag

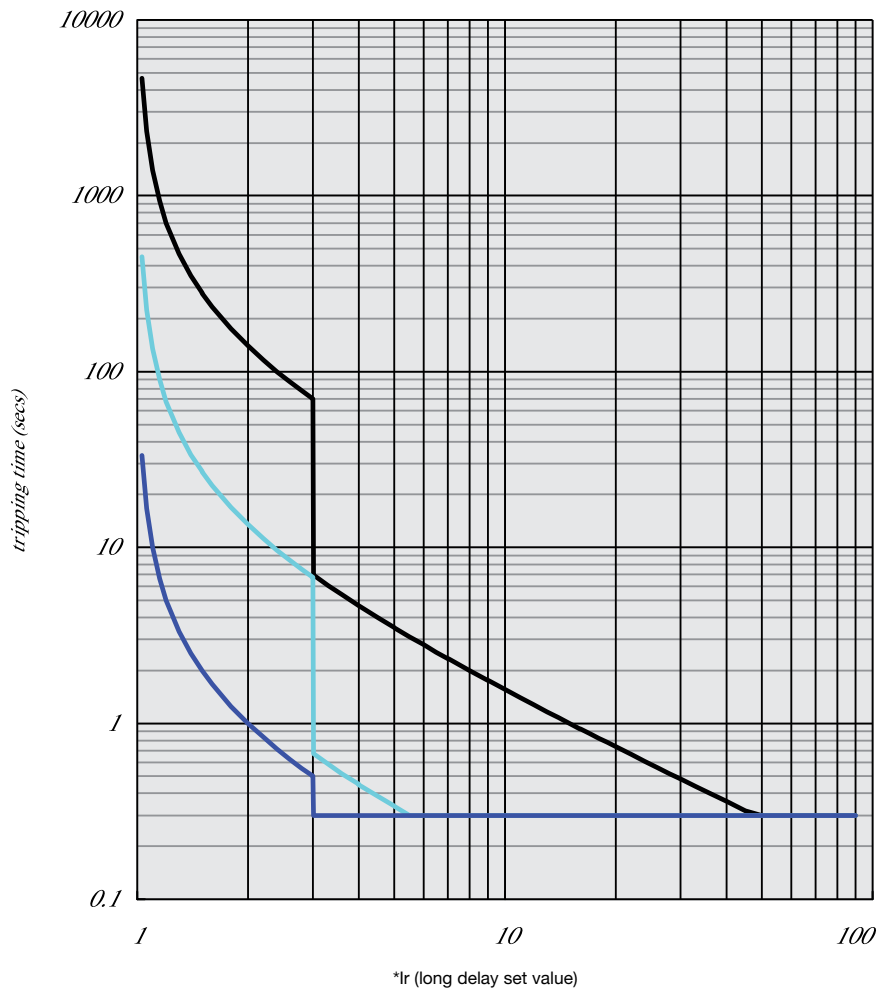

The curve above bases on the set value below:

- Curve type = fast reverse time lag
- Curve speed = C1, C8 and C16
- Operation set value of short delay reverse time lag = $3 \times I_{set}$
- Delay time of short delay fixed time lag set value = 0.3 S

Characteristics Curve

Micropro 2 - 7.1

Chart C2
Protection example of fixed time lag

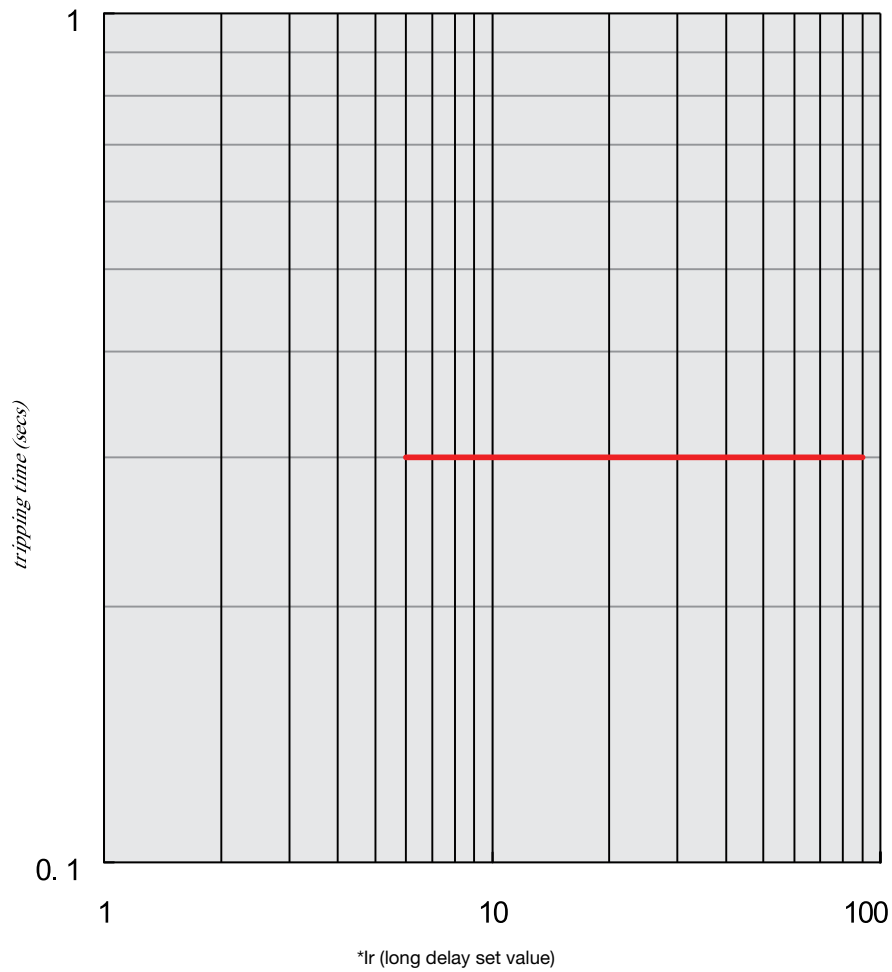

The curve above bases on the fixed value below:

- Delay time of short delay fixed time lag set value = $6 \times I_r$
- Delay time of short delay fixed time lag set value = 0.3 S

Characteristics Curve

Micropro 2 - 7.1

Chart C3

Example curve of reverse time lag, fixed time lag

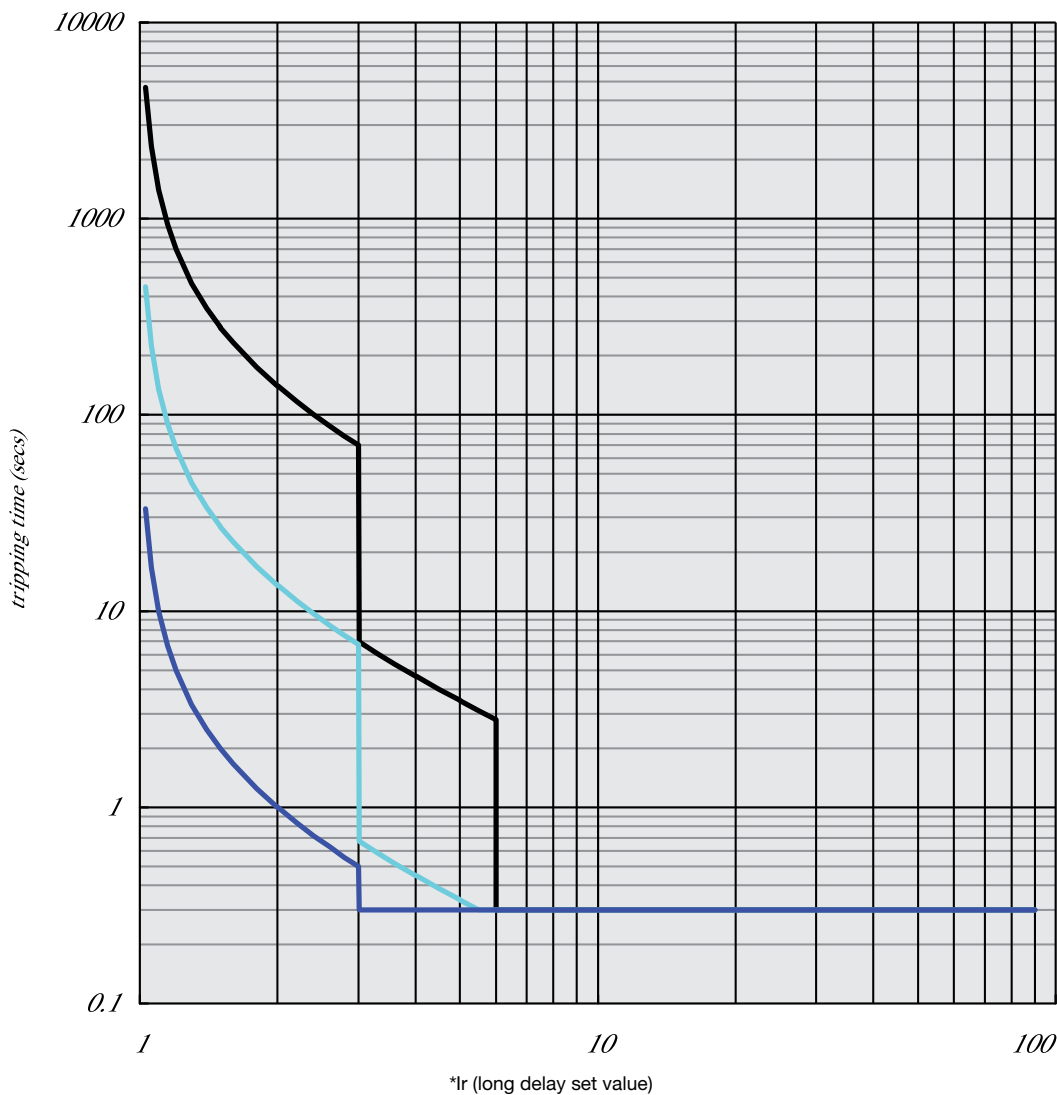

The curve above bases on the set value below:

- Curve type = fast reverse time lag
- Curve speed = C1, C8 and C16 (C1 fastest)
- Operation set value of short delay reverse time lag = 3 x Iset
- Operating set value of short delay fixed time lag = 6 x Ir
- Delay time of short delay fixed time lag set value = 0.3 S

Characteristics Curve

Micropro 2 - 7.1

Chart G1
Ground protection

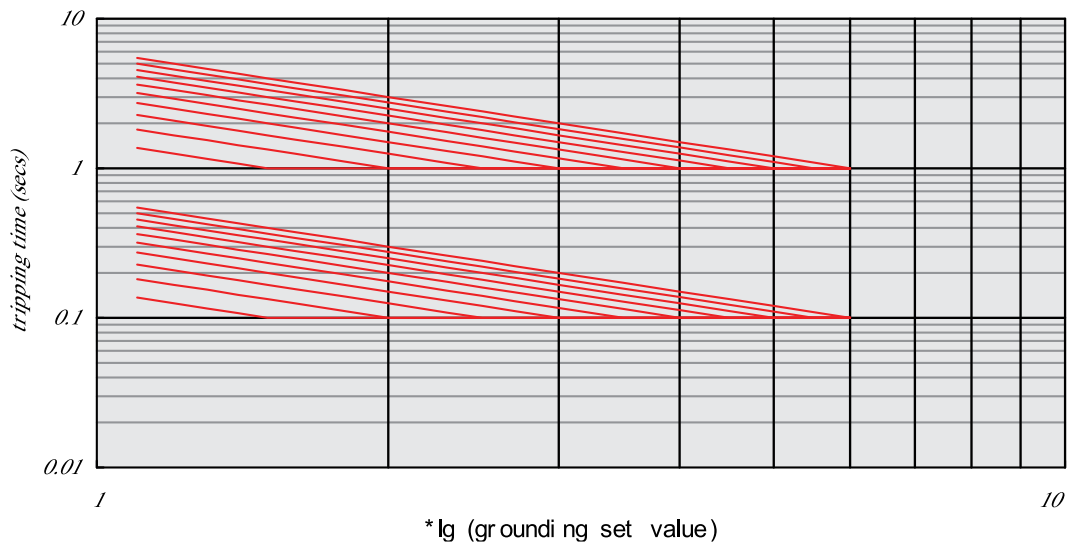
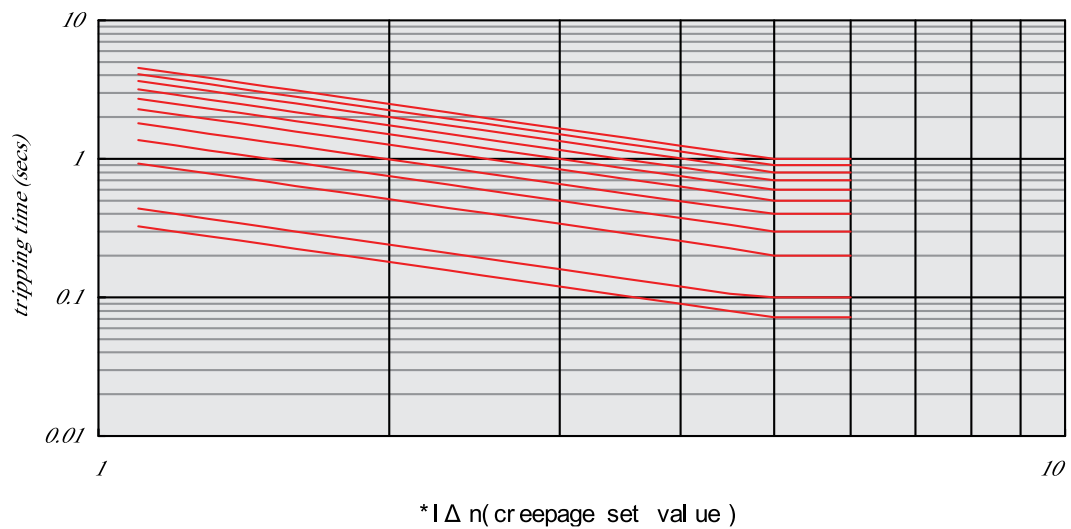

Chart G1
Creepage protection





Communication

Modbus / RS-485

- Operation Mode : Differential
- Distance : 1.2 km
- Cable : General RS-485 Shielded twist 2 pair cable
- Baud rate : 9600 bps, 19200 bps, 38400 bps
- Transmission Method : Half-duplex
- Termination : 100 Ω

Profibus - DP

- Profibus-DP Module is installed separately (optional)
- Operation Mode : Differential
- Distance : 1.2 km
- Cable : Profibus-DP Shielded twist 2 pair cable
- Baud rate : 9600 bps~12Mbps
- Transmission Method : Half-duplex
- Termination : 100
- Standard : EN 50170/DIN19245

ZSI - (micropro2)

ZSI – Zone Selective Interlocking (micropro2)

Zone selective interlocking drops delay time that eliminates fault for breakers. It minimize the shock that all kind of electric machineres get under fault conditions.

- In case of that short time-delay or ground fault accident occurs at ZSI built in system, the breaker at accident site sends ZSI signal to halt upstream breaker's operation.
- To eliminate a breakdown, trip relay of ACB at accident site activates trip operation without time delay.
- The upstream breaker that received ZSI signal adhere to pre-set short time delay or ground fault time-delay for protective coordination in the system. However upstream breaker that did not receive its signal will trip instantaneously
- Fpor ordinary ZSI operations it should arrange operation time accordingly so that downstream breaker will react before upstream ones under overcurrent/short time delay/ ground fault situations.
- ZSI connecting lines need to be Max. 3m.

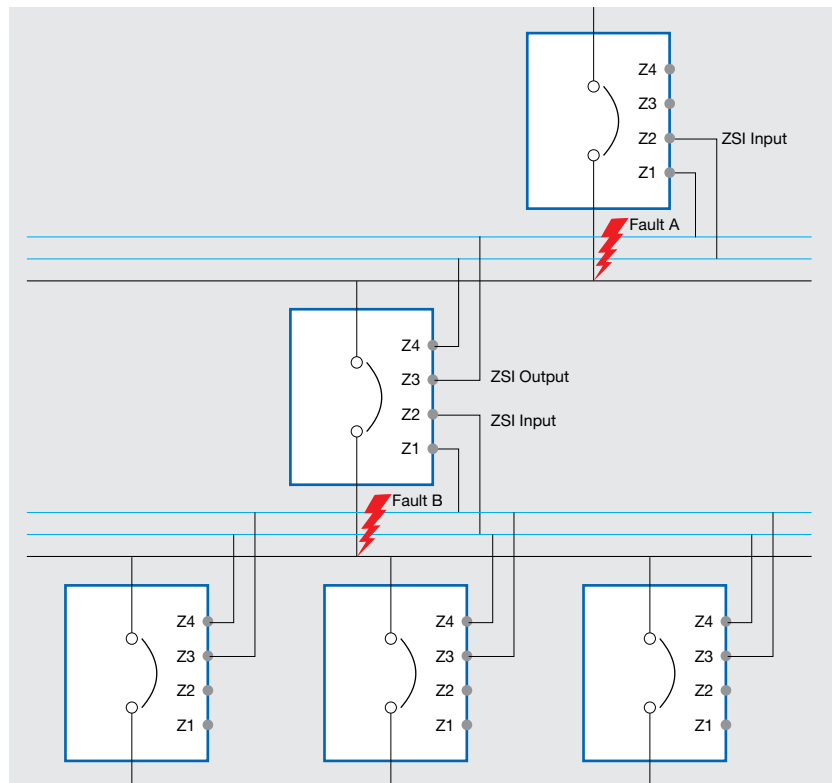

- 1) Occurrence of fault A
 - Only **Breaker 1** performs instantaneous trip operation
- 2) Occurrence of fault B
 - **Breaker 2** perform instantaneous trip operation, breaker 1 perform trip operation after prearranged delay time
 - But if **Breaker 2** did not break the fault normally, breaker 1 perform instantaneous trip operation to protect system.



Snap-in type Accessories

- Spring charging motor
- Opening / closing coil
- Under voltage release



Auxiliaries for remote operation



Electrical charging device (Motor)

Basic Function

The electrical charging device (motor) automatically charges & recharges the spring mechanism.

Features

- Voltages available - 220V AC (50Hz), 415V AC (50Hz), 110V DC, 220V DC.
- Consumption - 85VA for AC, 85W for DC



Opening release, closing release

Basic Function

- Opening release instantaneously opens the circuit breaker when energized.
- Closing release instantaneously closes the circuit breaker when energized.

Features

- Voltages available – 220V AC (50Hz), 415V AC (50Hz), 220V DC.
- Consumption - 24VA for 220V AC, 36VA for 415V AC, 24W for 220V DC.
- Reliable operating voltage range of opening release is 70% - 110%.
- Reliable operating voltage range of closing release is 85% - 110%.



Under voltage release

Basic Function

- The Under voltage release instantaneously opens the circuit breaker when the supply voltage drops.
- The delay block eliminate the nuisance tripping during short voltage dips.

Features

- Voltages available – 220V AC (50Hz), 415V AC (50Hz)
- Consumption - 24VA for 220V AC, 36VA for 415V AC,
- Characteristics of Under voltage release of circuit breaker

| Type | | Under-voltage release | Under-voltage release |
|-----------------------------------------------------------------|--------------|-------------------------------------------|-----------------------|
| Operating time of release | | Time delay 0, 0.3, 0.6, 1, 3, 5S | instantaneous |
| Operating voltage value of release | 35~70%Ue | It is able to open the circuit breaker | |
| Within of delay time; when the source voltage recovers to 85%Ue | ≤ 35%Ue | Circuit breaker is unable to close | |
| | ≥ 85%~110%Ue | Circuit breaker is able to close reliably | |
| | | Circuit breaker does not open | |

Note: Accuracy of delay time is ±10%.

Mechanical accessories



Mechanical Interlock

Basic Function

It is used to interlock closing & trip between two or three breakers mechanically so as to prevent unintended operation at the same time.

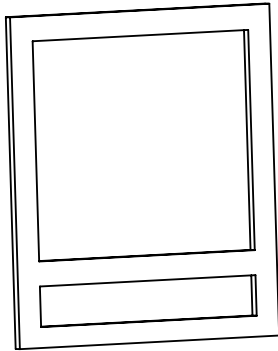

Panel door ingress seal

Basic Function

Panel door ingress seal increases the degree of protection to IPXX & IPXX in fix & drawout ACB simultaneously.

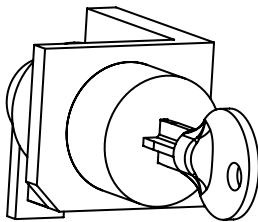

Keylock

Basic Function

- The key lock inhibits local & remote closing of circuit breaker.
- Interlocking can be achieved by using '2 locks with 1 key' & '3 locks with 2 keys'.

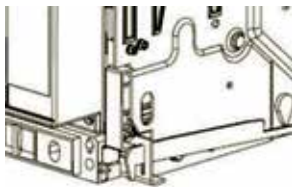

Door Interlock

Basic Function

- This device inhibits opening of the cubicle door when the circuit breaker is in 'Connected' or 'Test' position.
- It may be mounted on the left or right-hand side of the chassis.

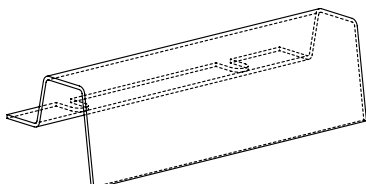

Auxiliary Terminal Shield

Basic Function

This shield prevents access to the terminal block of the electrical auxiliaries.

Electrical Diagram

Micropro 2 - 3.1

Micropro 2 - 3.1

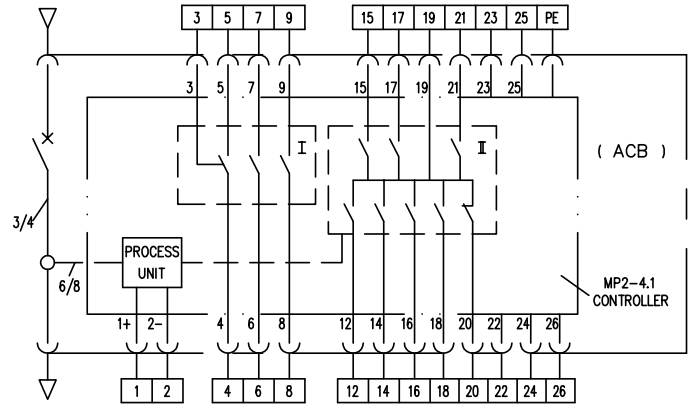
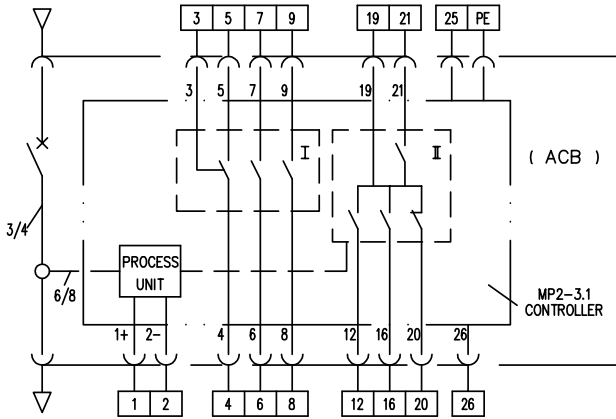

Micropro 2 - 7.1

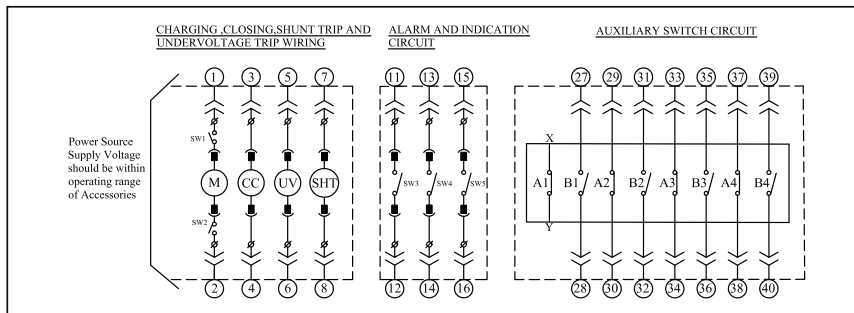
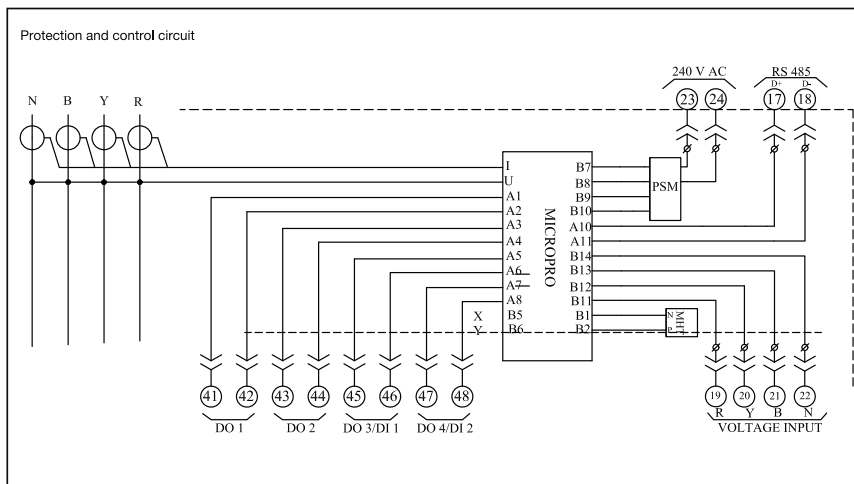

- PLUG AND SOCKET CONNECTION
 - BREAKER WIRING
 - ISOLATING CONTACT
- NOTE : SW2 WILL BE USED ONLY FOR DC MOTOR
- M --- Charging Motor
 - CC --- Closing Coil
 - UVT --- Under Voltage Trip Coil
 - SHT --- Shunt Trip Coil
 - MHT --- Magnetic Held Trigger Device
 - SW1 --- Motor CutOFF Switch
 - SW2 --- Motor CutOFF Switch(DC)
 - SW3 --- Trip Indication Switch
 - SW4 --- Charge Indication Switch
 - SW5 --- OCR Switch
 - SW6 --- MCR Switch

Identifying Electrical Auxiliaries

Electrical Diagram-additional features

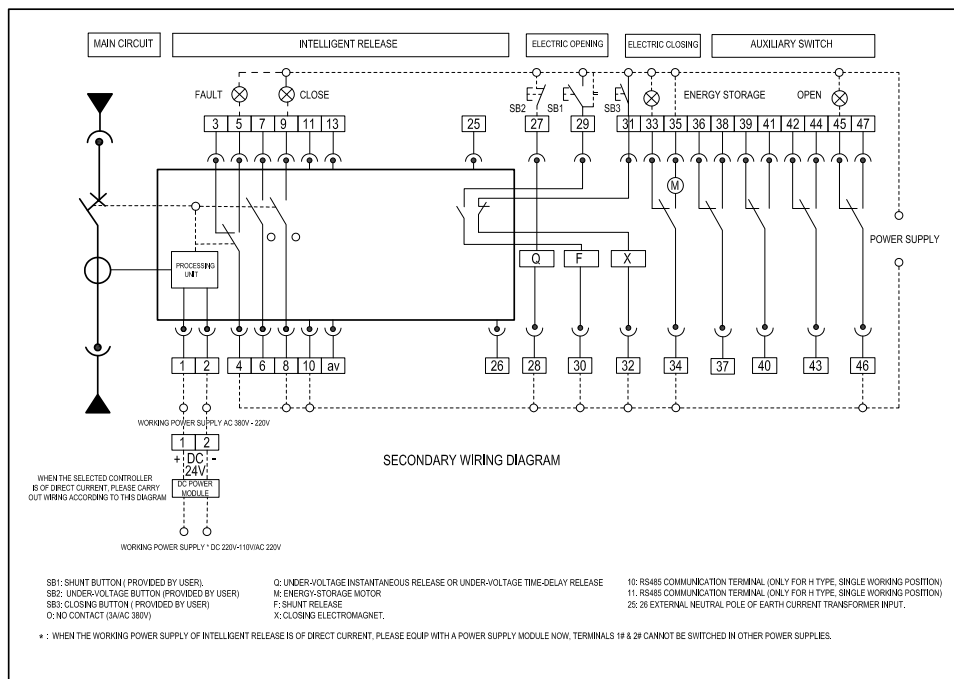

Electrical Diagram

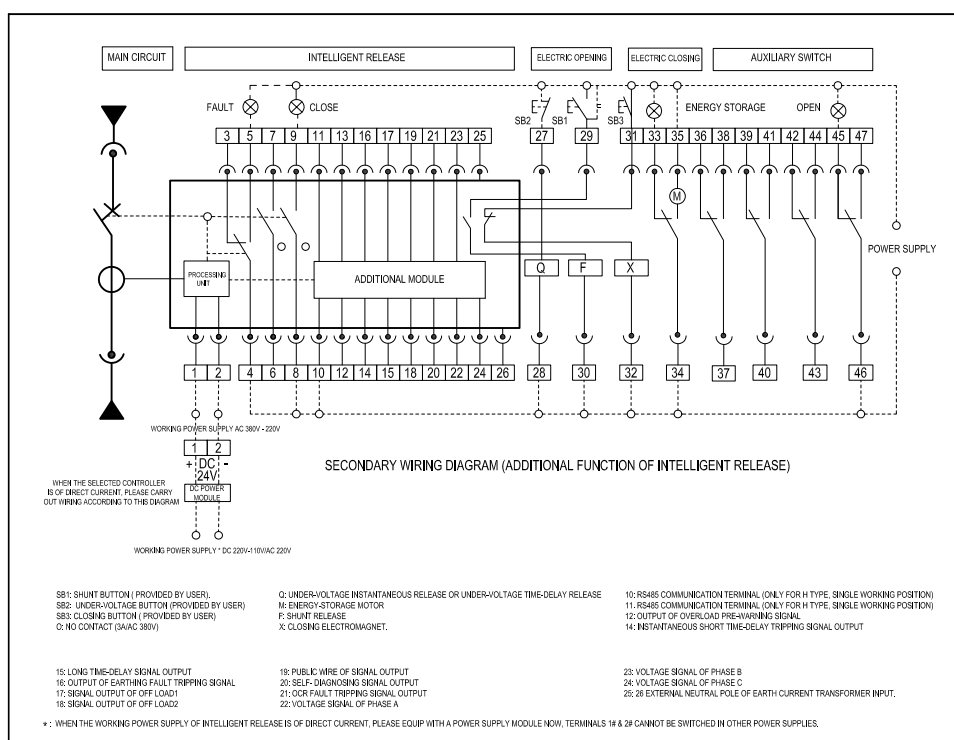

Identifying WX ACB

Model Description

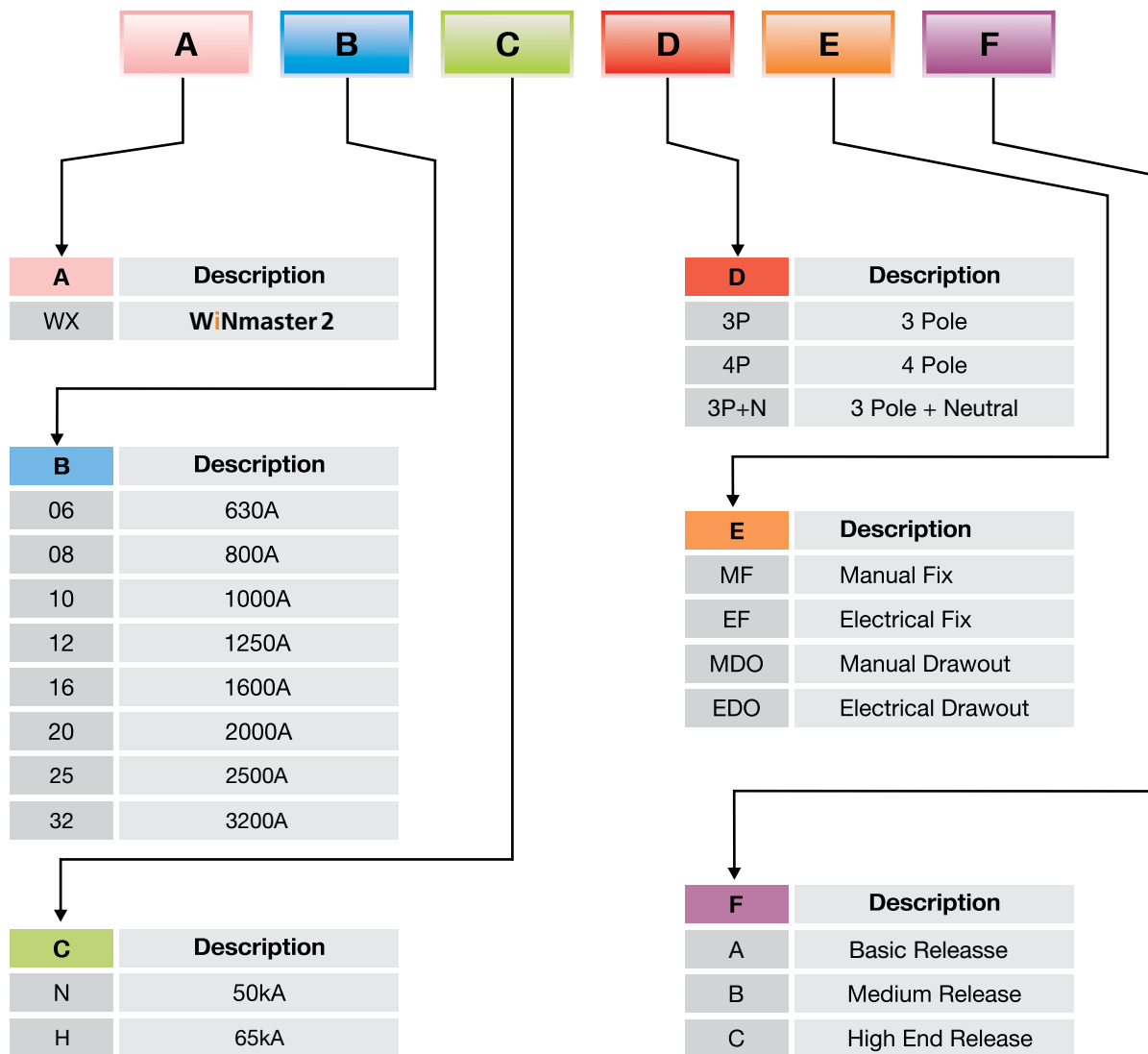

Example: WX ACB of 630A, 4 Pole, 50kA Electric Drawout with medium release;
product code shall be:

| A | B | C | D | E | F |
|----|----|---|----|-----|---|
| WX | 06 | N | 4P | EDO | B |

Nomenclature

Rating

WiNmaster 2 WX series Intelligent Circuit Breaker offer current ratings from 630A to 2500A. The new generation intelligent controller provided basic protection of distribution network with specialized function like Measurement, Maintenance and Man-Machine interface.

- 1 Manufacturer Logo
- 2 Brand Name
- 3 Applicable standards
- 4 Utilization Category
- 5 Qrcode

- 1
- 2
- 3
- 4

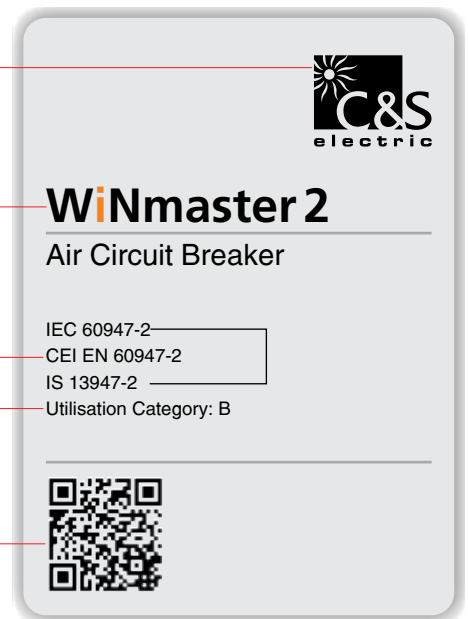

- 1 Suitability for isolation
- 2 ACB Code
- 3 Rated current
- 4 ACB Type
- 5 Rated operational voltage
- 6 Rated insulation voltage
- 7 Rated impulse voltage
- 8 Ultimate breaking capacity
- 9 Rated service breaking capacity
- 10 Rated short-time breaking capacity
- 11 ACB Cat.
- 12 CE Marking
- 13 Barcode

- 1
- 2
- 3
- 4
- 5
- 6
- 7
- 8
- 9
- 10
- 11
- 12
- 13

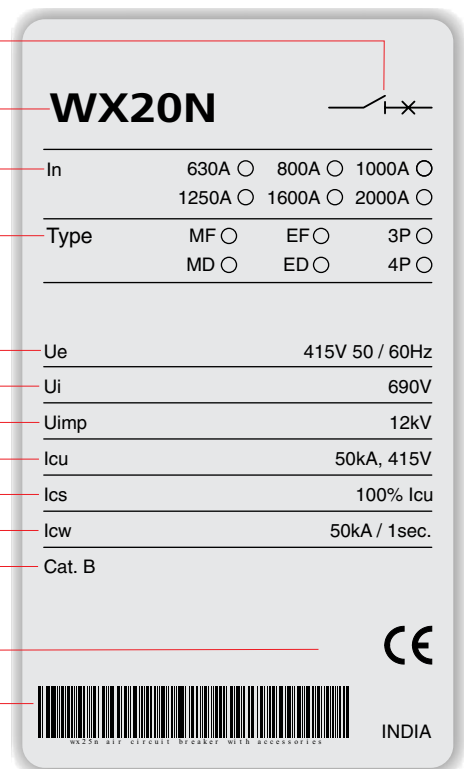

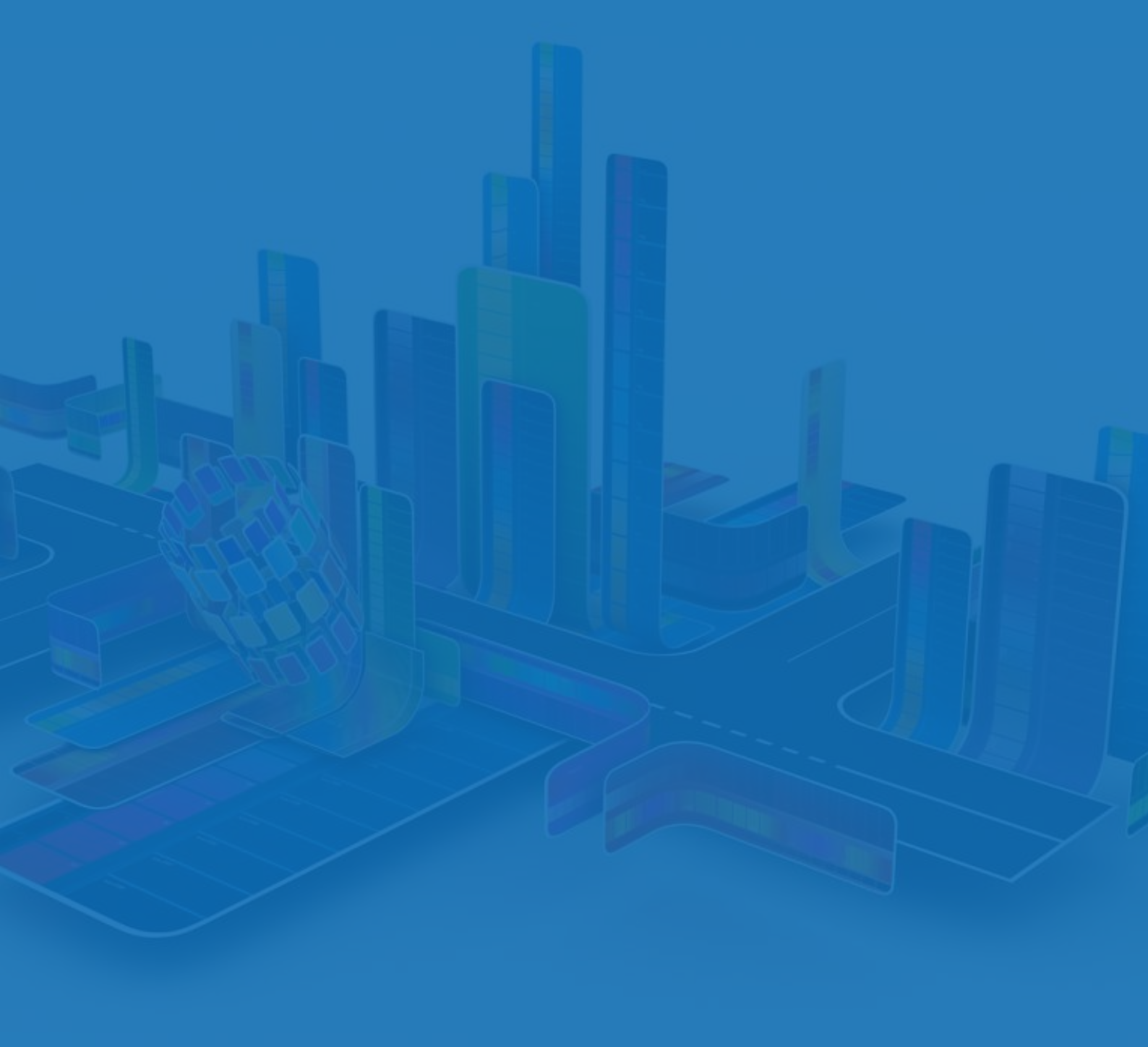

Dimensions

- Fixed type-630-2500A, 3P/4P
- Draw-out type-630-2500A, 3P/4P
- Fixed type - 3200A, 3P/4P
- Draw-out type - 3200A, 3P/4P
- Fixed type - Panel cutout dimension
- Draw-out type - Panel cutout dimension



Dimensions

Fixed type-630-2500A, 3P/4P

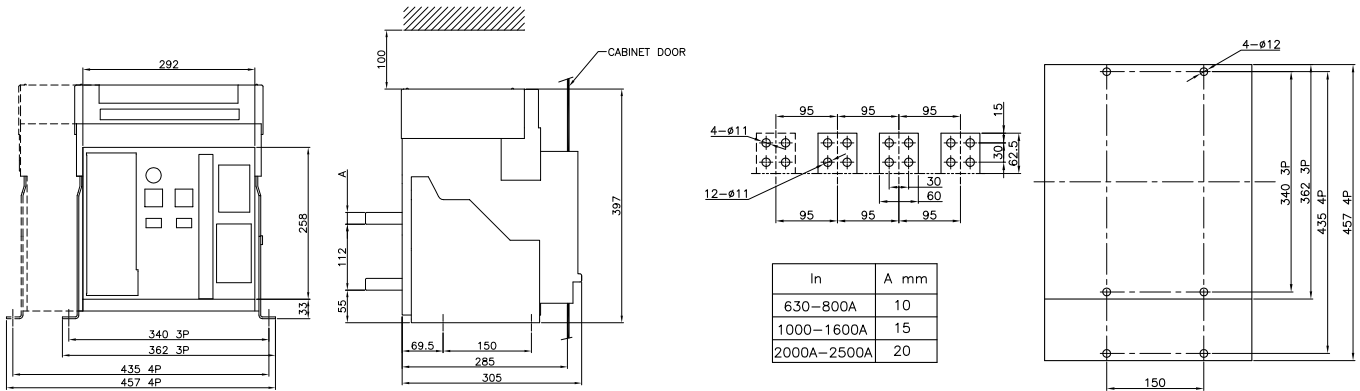

Draw-out type-630-2500A, 3P/4P

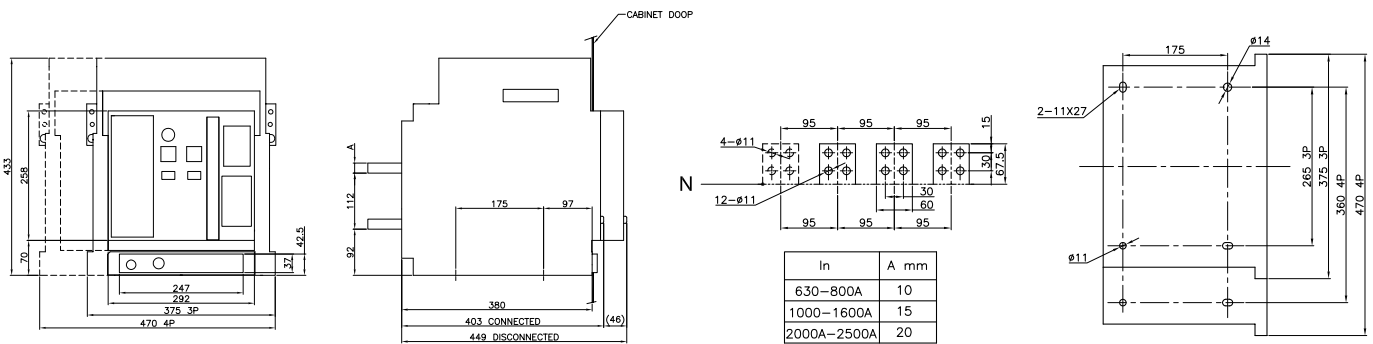

Fixed type - 3200A, 3P/4P

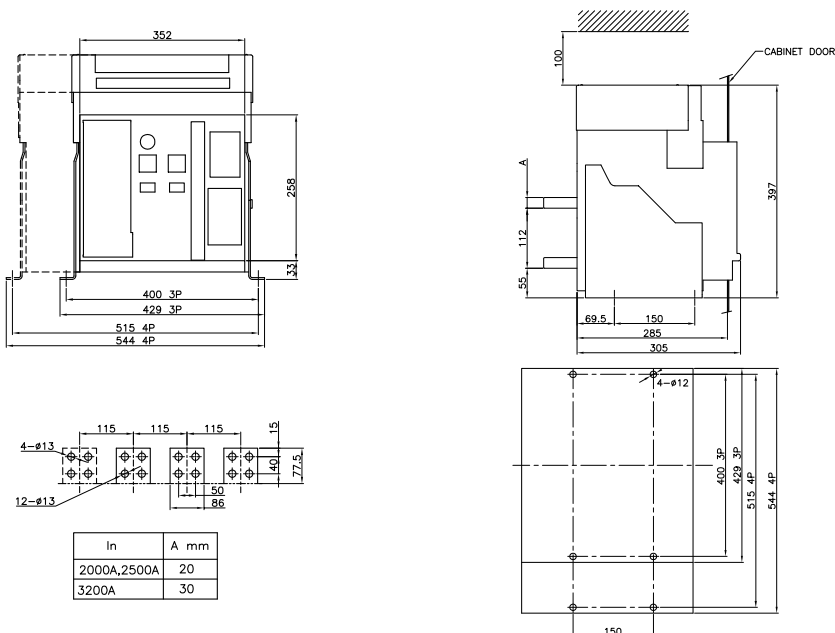

Draw-out type - 3200A, 3P/4P

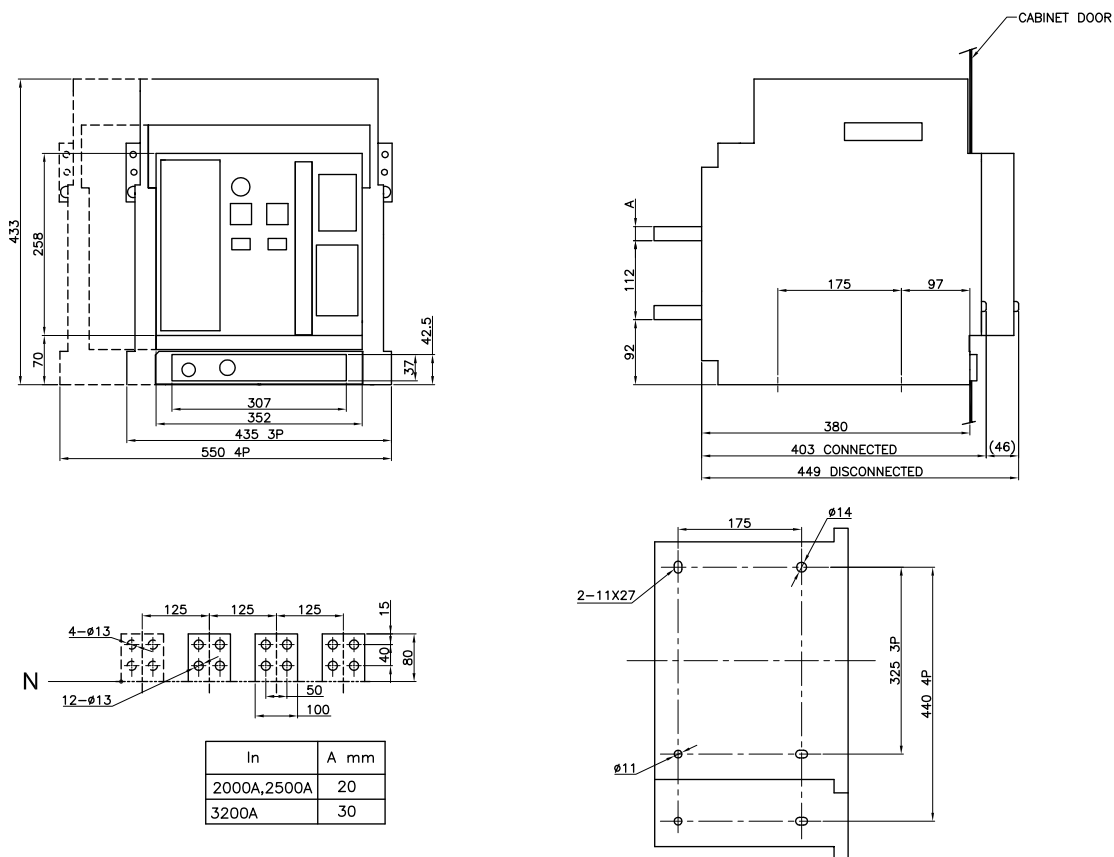

Fixed type - Panel cutout dimension

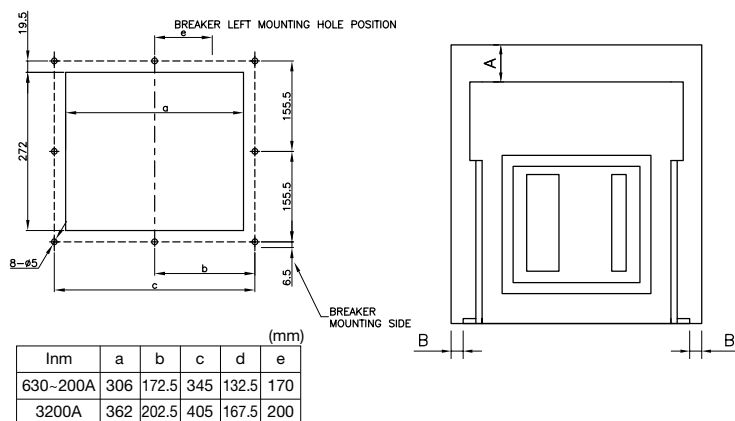

Draw-out type - Panel cutout dimension

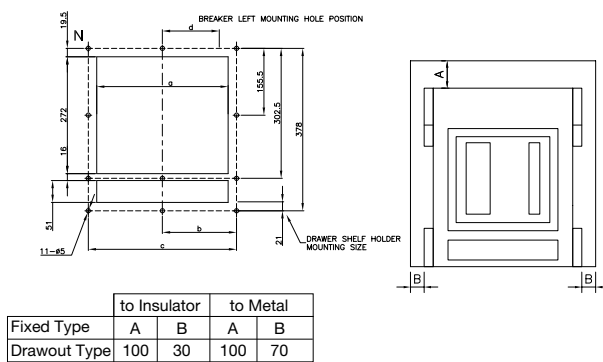

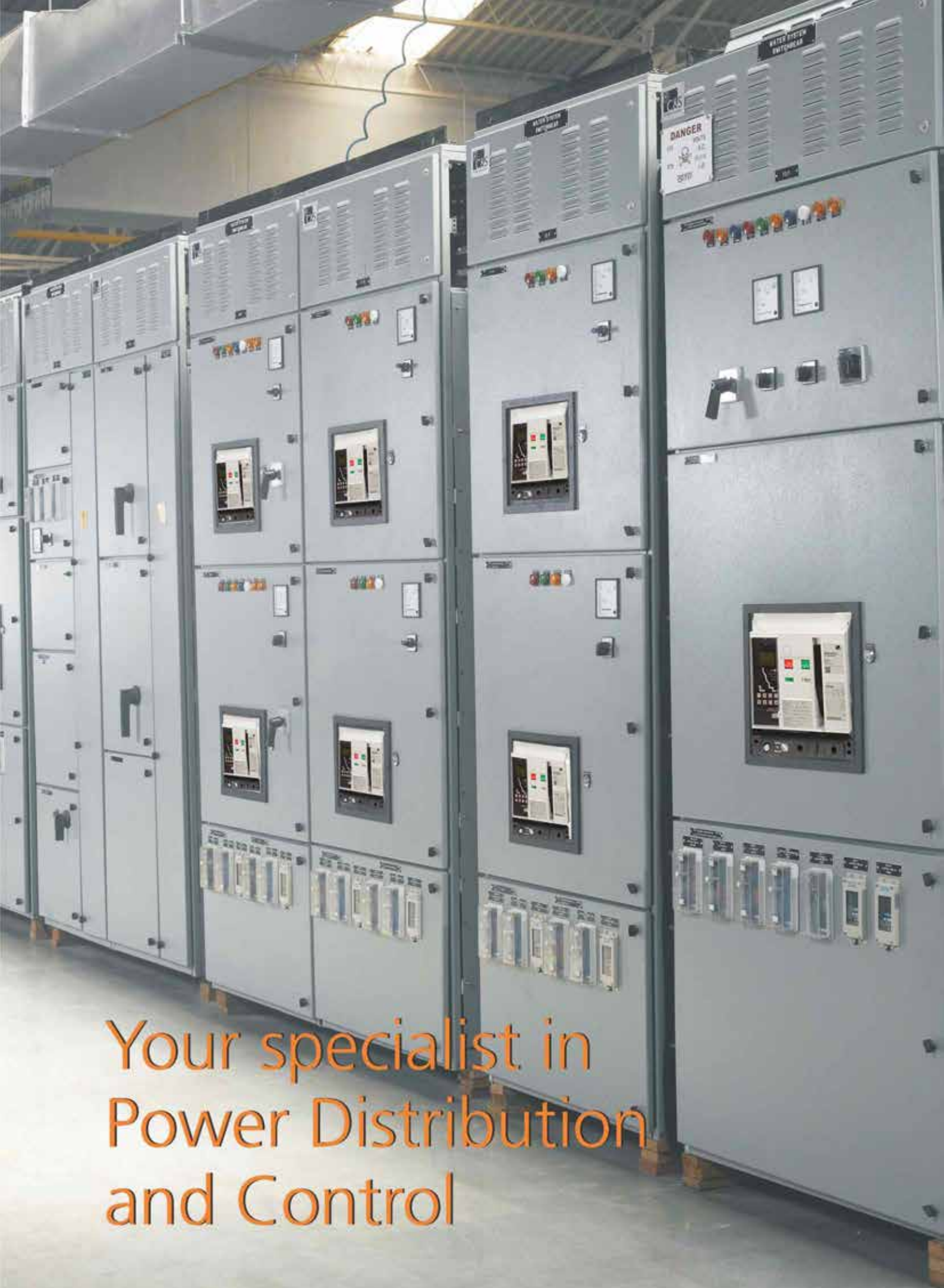

Your specialist in
Power Distribution
and Control

WiNmaster 2

www.cselectric.co.in

C&S Electric Ltd.

222, Okhla Industrial Estate, Phase-III, New Delhi - 110020, INDIA

Tel. : +91-11-3088 7520 - 29

Fax: +91-11-26838291, 2684 8241

E-mail : cmo@cselectric.co.in



We touch your electricity everyday!